

**Pitchlign<sup>®</sup>, TJ TandemRoller<sup>®</sup>, Inner Rings**

**Heavy Duty Needle Roller Bearings**

High load capacity, long life, caged roller bearings in standard configurations and custom designs



RBC Division  
ISO 9001:2000

[www.rbcbearings.com](http://www.rbcbearings.com)  
800.390.3300



RBC Bearings Incorporated (RBC Bearings, RBC) has had a long tradition of innovation, commitment, and quality since the company was founded in 1919. Today, RBC Bearings has grown into a world-class manufacturer of standard and custom-engineered bearings and related products, with a product focus on research, testing, and development of the best product for specific applications.

## What We Manufacture

RBC Bearings, with facilities throughout North America and Europe, provides bearings and precision products for applications in the construction, mining, material handling, transportation and off-highway equipment, robotics and automation, farming, machine tool, and semiconductor equipment industries. Through RBC Aerospace Bearings, the company is a major manufacturer of highly-engineered bearings and precision products for military, defense, and commercial aerospace applications.

RBC's high-quality bearings include:

- **Heavy Duty Needle Roller Bearings** - Pitchlign® caged heavy duty needle roller bearings, inner rings, TJ TandemRoller® bearings for long life.
- **Spherical Plain Bearings** - Radial, angular, contact, high misalignment, extended inner ring, DuraLube™ maintenance-free spherical plain bearings, QuadLube® long life bearings, ImpactTuff® case carburized bearings, ShimPack® double-acting angular contact bearings, CrossLube® lubrication groove systems, and SpreadLock® Seal.
- **Cam Followers and Yoke Rollers** - Standard stud, heavy stud, yoke type, caged roller followers, RBC Roller® long life cam followers, HexLube® universal cam followers, airframe track rollers. Mastguide rollers and carriage rollers, chain sheaves (for leaf chain), toothless sprockets (for roller chain), and heavy-duty roller bearing construction.
- **Rod Ends** - Commercial and aerospace, precision, Mil-Spec series, self-lubricating, inch and metric. Heim®, Unibal®, and Spherco® brands.
- **Self-Lubricating Bearings** - Radial, thrust, rod ends, spherical plain bearings, high temperature, high loads, inch and metric. Fiberglide® brand.
- **Thin Section Ball Bearings** - Standard cross sections to one inch. Sizes to 40 inches. Stainless steel and other materials available. Seals available on all sizes and standard cross sections.
- **Airframe Control Bearings** - Ball bearing types, self-lubricating types, needle rollers, track rollers.
- **Ground, Semiground, and Unground Ball Bearings** - Full complement, utilizes design and burnished races for higher loads, long life, and smooth operation.
- **Dowel Pins, Loose Needle Rollers, Shafts**
- **Tapered Roller Bearings** - Case-hardened and through-hardened in a variety of sizes, used in Class 8 heavy truck and trailer wheel bearings, final drive transmissions and gear boxes.
- **Tapered Roller Thrust Bearings** - Case-hardened. Sealed and unsealed for truck, tractor, and construction equipment steer axles, and Class 8 trailer landing gear.
- **Ball Screws** - Precision ground, rolled, ball splines. Long life, low wear, high accuracy, QuickTurn® Ball Screw Repair Service.
- **Custom Designed Bearings** - RBC produces a wide range of custom bearings in various materials for specific applications.

## RBC Heavy Duty Needle Roller Bearings

RBC produces an extensive heavy duty needle roller bearing product line from 1 inch outer ring OD to 12.125 inch outer ring OD. RBC heavy duty needle roller bearings can be found in helicopter rotors and transmissions, marine crankshafts and connecting rods, gear pumps, oil field pumping jacks, and mud pumps.

The RBC SJ series of Pitchlign® heavy duty needle roller bearings are supplied in standard envelopes in both sealed and unsealed configurations.

RBC TJ TandemRoller® heavy duty needle roller bearings increase the capacity of the standard Pitchlign® SJ series from 10% to 40% while maintaining the standard SJ envelope.

RBC inner rings can be used separately or as an inner race for complimentary SJ or TJ roller bearings.

RBC produces metric roller bearings where volume permits.

## How We Can Serve You

RBC has implemented a total quality control system that uses statistical quality control at all facilities, and manufactures in high volume to a just-in-time program.

To serve the ongoing needs of customers, RBC has a network of over 1,600 distributors and sales engineers throughout North and South America and Europe, with authorized agents worldwide. For assistance with your bearing application, contact:

**Customer Service - 800.390.3300**

## Warranty

RBC products are warranted for material and workmanship for a period not to exceed 90 days from shipment and for a value not to exceed purchase price. No other warranty is in effect.

### Disclaimer and Intellectual Property Statement

The materials comprising this Catalog are provided by RBC Bearings Incorporated ("RBC Bearings, RBC") as a service to its customers on an "as-is" basis for informational purposes only. RBC assumes no responsibility for any errors or omissions in these materials. RBC makes no commitment to update the information contained herein.

RBC makes no, and expressly disclaims any, representations or warranties, express or implied, regarding the Catalog, including, without limitation, any implied warranties of merchantability or fitness for a particular purpose. RBC makes no, and expressly disclaims any, warranties, express or implied, regarding the correctness, accuracy, completeness, timeliness, and reliability of the text, graphics and any other items in the Catalog. Under no circumstances shall RBC, its affiliates, or any of their respective partners, officers, directors, employees, agents or representatives be liable for any damages, whether direct, indirect, special or consequential damages for lost revenues, lost profits, or otherwise, arising from or in connection with this Catalog and the materials contained herein.

All materials contained in the Catalog are protected by copyright laws, and may not be reproduced, republished, distributed, transmitted, displayed, broadcast or otherwise exploited in any manner without the express prior written permission of RBC.

RBC's names and logos and all related trademarks (including RBC part numbers, series number, and cone and cup numbers), tradenames, and other intellectual property are the property of RBC Bearings and cannot be used without its express prior written permission.



# TABLE OF CONTENTS

Precision Ground Heavy Duty Needle Roller Bearings	2 - 7	
Precision Ground Heavy Duty Needle Roller Bearings with Seals	8 - 9	
Inner Rings for Precision Ground Heavy Duty Needle Roller Bearings	10 - 12	
TandemRoller® Bearings — TJ, DTJ Series	13 - 15	
Technical Data	16 - 17	$C_{req} = P_e \cdot \left( \frac{L_{10} \cdot n_e}{16667} \right)^{0.3}$
Typical Applications	18 - 19	
Pitchlign® Roller Bearing Interchange Tables	20 - 25	
Pitchlign® Application Sheet	26 - 28	
Custom Designed Bearings	29	
Other RBC Bearings Products		Back Cover 

# Precision Ground Heavy Duty Needle Roller Bearings

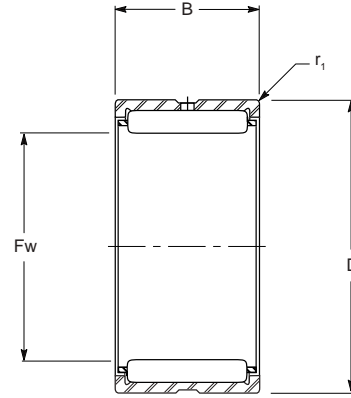

## SJ Pitchlign® Series

BEARING PART NUMBER	Fw Inside Diameter			D Outside Diameter		B Width +.000 -.005	r <sub>1</sub> Housing Fillet Max.	Approx. Weight (lbs.)	Housing Shoulder Dia. +/- 1/64"	Dynamic Capacity C (lbs.)	Static Capacity C <sub>0</sub> (lbs.)
	Nominal	Min.	Max.	Max.	Min.						
SJ 7113	1/2	.5005	.5014	1.0000	.9995	.750	.04	.110	11/16	2,700	3,500
SJ 7123	9/16	.5630	.5639	1.0625	1.0620	.750	.04	.117	3/4	2,900	3,900
SJ 7133*	5/8	.6258	.6267	1.1250	1.1245	.750	.04	.109	15/16	3,900	4,800
SJ 7134*	5/8	.6258	.6267	1.1250	1.1245	1.000	.04	.137	15/16	5,200	7,000
SJ 7153*	3/4	.7509	.7518	1.2500	1.2495	.750	.04	.112	1 1/16	4,500	6,000
SJ 7154*	3/4	.7509	.7518	1.2500	1.2495	1.000	.04	.152	1 1/16	6,000	8,700
SJ 7163	13/16	.8134	.8143	1.3125	1.3120	.750	.04	.140	1 1/16	3,800	5,400
SJ 7173*	7/8	.8759	.8768	1.3750	1.3745	.750	.04	.125	1 3/16	4,700	6,700
SJ 7174*	7/8	.8759	.8768	1.3750	1.3745	1.000	.04	.169	1 3/16	6,300	9,700
SJ 7183	15/16	.9384	.9393	1.4375	1.4370	.750	.04	.152	1 3/16	4,300	6,400
SJ 7193*	1	1.0009	1.0018	1.5000	1.4995	.750	.04	.151	1 5/16	5,200	7,900
SJ 7194*	1	1.0009	1.0018	1.5000	1.4995	1.000	.04	.190	1 5/16	7,000	11,400
SJ 7204	1 1/16	1.0634	1.0643	1.5625	1.5620	1.000	.04	.235	1 5/16	6,000	10,300
SJ 7205	1 1/16	1.0634	1.0643	1.5625	1.5620	1.250	.04	.280	1 5/16	7,500	13,600
SJ 7214*	1 1/8	1.1259	1.1268	1.6250	1.6245	1.000	.04	.212	1 3/8	7,600	13,200
SJ 7215*	1 1/8	1.1259	1.1268	1.6250	1.6245	1.250	.04	.229	1 3/8	9,400	17,300
SJ 7224	1 3/16	1.1885	1.1894	1.6875	1.6870	1.000	.04	.262	1 7/16	6,700	11,800
SJ 7234*	1 1/4	1.2510	1.2519	1.7500	1.7495	1.000	.04	.242	1 9/16	7,900	14,200
SJ 7235*	1 1/4	1.2510	1.2519	1.7500	1.7495	1.250	.04	.310	1 9/16	9,700	18,600
SJ 7244	1 5/16	1.3135	1.3144	1.8125	1.8120	1.000	.04	.290	1 9/16	7,000	13,300
SJ 7245	1 5/16	1.3135	1.3144	1.8125	1.8120	1.250	.04	.350	1 9/16	8,800	17,600
SJ 7254*	1 3/8	1.3760	1.3769	1.8750	1.8745	1.000	.04	.250	1 11/16	8,400	15,900
SJ 7255*	1 3/8	1.3760	1.3769	1.8750	1.8745	1.250	.04	.315	1 11/16	8,600	17,600
SJ 7264	1 7/16	1.4385	1.4394	1.9375	1.9370	1.000	.04	.315	1 11/16	7,200	14,200
SJ 7274*	1 1/2	1.5010	1.5019	2.0625	2.0619	1.000	.06	.317	1 13/16	8,100	16,000
SJ 7275*	1 1/2	1.5010	1.5019	2.0625	2.0619	1.250	.06	.400	1 13/16	11,500	23,000
SJ 7284	1 9/16	1.5635	1.5644	2.1250	2.1244	1.000	.06	.342	1 13/16	7,600	15,700
SJ 7285	1 9/16	1.5635	1.5644	2.1250	2.1244	1.250	.06	.423	1 13/16	9,400	20,700
SJ 7294*	1 5/8	1.6260	1.6269	2.1875	2.1869	1.000	.06	.342	1 15/16	10,000	19,500
SJ 7295*	1 5/8	1.6260	1.6269	2.1875	2.1869	1.250	.06	.431	1 15/16	12,400	25,600

All dimensions in inches.

For matching inner rings see **page 10**

The part numbers of matching inner rings are the same as the corresponding bearing numbers, except the prefix **SJ** is replaced by the prefix **IR**

Alternate inner rings with different bores are available for several bearings.

Alternate inner rings carry suffix **-C** or **-D**.

- Example: Matching inner rings for bearing **SJ 7315** (1 1/34" x 2 5/8" x 1 1/4"):
- a) **IR 7315** (1 7/16"ID x 1 3/4"OD x 1 1/4"W)
  - or
  - b) **IR 7315 C** (1 1/2"ID x 1 3/4"OD x 1 1/4"W)
- Inner rings must be ordered separately**

# Precision Ground Heavy Duty Needle Roller Bearings with Inner Rings



For matching inner rings see [Page 10](#)

Limit Speed (rpm)	Recommended Shaft Diameter				Recommended Housing Bore						MS 51961 Suffix	BEARING PART NUMBER
	ISO h6, use with H7 hsg fit		ISO f6, use with N7 hsg fit		Slip Fit ISO H7			Press Fit ISO N7				
	Max.	Min.	Max.	Min.	Min.	Max.	Mean Fit	Min.	Max.	Mean Fit		
26,000	.5000	.4996	.4994	.4989	1.0000	1.0008	.0006L	.9989	.9997	.0004T		<b>SJ 7113</b>
23,000	.5625	.5621	.5619	.5614	1.0625	1.0633	.0006L	1.0614	1.0622	.0004T		<b>SJ 7123</b>
21,000	.6250	.6246	.6244	.6239	1.1250	1.1258	.0006L	1.1239	1.1247	.0004T	-1	<b>SJ 7133*</b>
21,000	.6250	.6246	.6244	.6239	1.1250	1.1258	.0006L	1.1239	1.1247	.0004T		<b>SJ 7134*</b>
17,000	.7500	.7495	.7492	.7487	1.2500	1.2510	.0007L	1.2487	1.2497	.0005T	-2	<b>SJ 7153*</b>
17,000	.7500	.7495	.7492	.7487	1.2500	1.2510	.0007L	1.2487	1.2497	.0005T	-3	<b>SJ 7154*</b>
16,000	.8125	.8120	.8117	.8112	1.3125	1.3135	.0007L	1.3112	1.3122	.0005T	-4	<b>SJ 7163</b>
15,000	.8750	.8745	.8742	.8737	1.3750	1.3760	.0007L	1.3737	1.3747	.0005T	-5	<b>SJ 7173*</b>
15,000	.8750	.8745	.8742	.8737	1.3750	1.3760	.0007L	1.3737	1.3747	.0005T	-6	<b>SJ 7174*</b>
14,000	.9375	.9370	.9367	.9362	1.4375	1.4385	.0007L	1.4362	1.4372	.0005T	-7	<b>SJ 7183</b>
13,000	1.0000	.9995	.9992	.9987	1.5000	1.5010	.0007L	1.4987	1.4997	.0005T	-8	<b>SJ 7193*</b>
13,000	1.0000	.9995	.9992	.9987	1.5000	1.5010	.0007L	1.4987	1.4997	.0005T	-9	<b>SJ 7194*</b>
12,000	1.0625	1.0620	1.0617	1.0612	1.5625	1.5635	.0007L	1.5612	1.5622	.0005T	-10	<b>SJ 7204</b>
12,000	1.0625	1.0620	1.0617	1.0612	1.5625	1.5635	.0007L	1.5612	1.5622	.0005T		<b>SJ 7205</b>
12,000	1.1250	1.1245	1.1242	1.1237	1.6250	1.6260	.0007L	1.6237	1.6247	.0005T	-11	<b>SJ 7214*</b>
12,000	1.1250	1.1245	1.1242	1.1237	1.6250	1.6260	.0007L	1.6237	1.6247	.0005T	-12	<b>SJ 7215*</b>
11,000	1.1875	1.1869	1.1865	1.1859	1.6875	1.6885	.0007L	1.6862	1.6872	.0005T	-13	<b>SJ 7224</b>
11,000	1.2500	1.2494	1.2490	1.2484	1.7500	1.7510	.0007L	1.7487	1.7497	.0005T	-14	<b>SJ 7234*</b>
11,000	1.2500	1.2494	1.2490	1.2484	1.7500	1.7510	.0007L	1.7487	1.7497	.0005T	-15	<b>SJ 7235*</b>
10,000	1.3125	1.3119	1.3115	1.3109	1.8125	1.8135	.0007L	1.8112	1.8122	.0005T	-16	<b>SJ 7244</b>
10,000	1.3125	1.3119	1.3115	1.3109	1.8125	1.8135	.0007L	1.8112	1.8122	.0005T	-17	<b>SJ 7245</b>
10,000	1.3750	1.3744	1.3740	1.3734	1.8750	1.8760	.0007L	1.8737	1.8747	.0005T	-18	<b>SJ 7254*</b>
10,000	1.3750	1.3744	1.3740	1.3734	1.8750	1.8760	.0007L	1.8737	1.8747	.0005T	-19	<b>SJ 7255*</b>
9,000	1.4375	1.4369	1.4365	1.4359	1.9375	1.9385	.0007L	1.9362	1.9372	.0005T	-20	<b>SJ 7264</b>
9,000	1.5000	1.4994	1.4990	1.4984	2.0625	2.0637	.0009L	2.0610	2.0621	.0006T	-21	<b>SJ 7274*</b>
9,000	1.5000	1.4994	1.4990	1.4984	2.0625	2.0637	.0009L	2.0610	2.0621	.0006T	-22	<b>SJ 7275*</b>
8,500	1.5625	1.5619	1.5615	1.5609	2.1250	2.1262	.0009L	2.1235	2.1246	.0006T		<b>SJ 7284</b>
8,500	1.5625	1.5619	1.5615	1.5609	2.1250	2.1262	.0009L	2.1235	2.1246	.0006T	-23	<b>SJ 7285</b>
8,000	1.6250	1.6244	1.6240	1.6234	2.1875	2.1887	.0009L	2.1860	2.1871	.0006T	-24	<b>SJ 7294*</b>
8,000	1.6250	1.6244	1.6240	1.6234	2.1875	2.1887	.0009L	2.1860	2.1871	.0006T	-25	<b>SJ 7295*</b>

The bearings meet Military Standard MS 51961.

\* These bearings have a radius at both ends of the outer ring.

All other outer rings are manufactured with a radius at one end and a break corner at the other.

# Precision Ground Heavy Duty Needle Roller Bearings

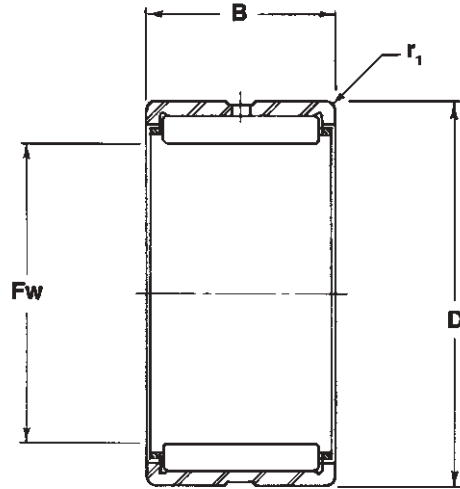

## SJ Pitchlign® Series

BEARING PART NUMBER	Fw Inside Diameter			D Outside Diameter		B Width +.000 -.005	r <sub>1</sub> Housing Fillet Max.	Approx. Weight (lbs.)	Housing Shoulder Dia. +/- 1/64"	Dynamic Capacity C (lbs.)	Static Capacity C <sub>0</sub> (lbs.)
	Nominal	Min.	Max.	Max.	Min.						
SJ 7304	1 11/16	1.6885	1.6895	2.2500	2.2494	1.000	.06	.37	1 15/16	7,600	15,900
SJ 7305	1 11/16	1.6885	1.6895	2.2500	2.2494	1.250	.06	.46	1 15/16	9,500	21,100
SJ 7314*	1 3/4	1.7510	1.7520	2.3125	2.3119	1.000	.06	.36	2 1/16	9,900	19,700
SJ 7315*	1 3/4	1.7510	1.7520	2.3125	2.3119	1.250	.06	.46	2 1/16	12,400	26,100
SJ 7324	1 13/16	1.8135	1.8145	2.3750	2.3744	1.000	.06	.40	2 1/16	8,000	17,300
SJ 7325	1 13/16	1.8135	1.8145	2.3750	2.3744	1.250	.06	.49	2 1/16	10,000	23,100
SJ 7334*	1 7/8	1.8760	1.8770	2.4375	2.4369	1.000	.06	.38	2 3/16	10,400	21,500
SJ 7335*	1 7/8	1.8760	1.8770	2.4375	2.4369	1.250	.06	.48	2 3/16	12,900	26,600
SJ 7344	1 15/16	1.9385	1.9395	2.5000	2.4994	1.000	.06	.42	2 3/16	8,100	18,100
SJ 7345	1 15/16	1.9385	1.9395	2.5000	2.4994	1.250	.06	.53	2 3/16	10,100	24,100
SJ 7354*	2	2.0011	2.0021	2.5625	2.5619	1.000	.06	.40	2 5/16	10,700	22,500
SJ 7355*	2	2.0011	2.0021	2.5625	2.5619	1.250	.06	.51	2 5/16	13,300	29,900
SJ 8406	2 1/4	2.2511	2.2521	3.0000	2.9994	1.500	.08	1.07	2 5/8	15,100	33,200
SJ 8407	2 1/4	2.2511	2.2521	3.0000	2.9994	1.750	.08	1.25	2 5/8	17,600	40,500
SJ 8446	2 1/2	2.5011	2.5021	3.2500	3.2494	1.500	.08	1.18	2 7/8	15,800	36,400
SJ 8447	2 1/2	2.5011	2.5021	3.2500	3.2494	1.750	.08	1.38	2 7/8	18,400	44,500
SJ 8476	2 3/4	2.7511	2.7521	3.5000	3.4992	1.500	.08	1.26	3 1/8	16,400	39,600
SJ 8477	2 3/4	2.7511	2.7521	3.5000	3.4992	1.750	.08	1.47	3 1/8	19,200	48,400
SJ 8516	3	3.0011	3.0023	3.7500	3.7492	1.500	.08	1.35	3 3/8	17,500	44,200
SJ 8517	3	3.0011	3.0023	3.7500	3.7492	1.750	.08	1.57	3 3/8	20,400	54,100
SJ 8536	3 1/8	3.1261	3.1273	4.0000	3.9992	1.500	.08	1.40	3 1/2	17,800	45,800
SJ 8537	3 1/8	3.1261	3.1273	4.0000	3.9992	1.750	.08	1.63	3 1/2	20,800	56,000
SJ 9567	3 1/4	3.2512	3.2524	4.2500	4.2492	1.750	.10	2.35	3 11/16	23,500	55,100
SJ 9568	3 1/4	3.2512	3.2524	4.2500	4.2492	2.000	.10	2.69	3 11/16	26,800	65,500

All dimensions in inches.

For matching inner rings see **page 11**

The part numbers of matching inner rings are the same as the corresponding bearing numbers, except that the prefix **SJ** is replaced by the prefix **IR**.

Alternate inner rings with different bores are available for several bearings.

Alternate inner rings carry the suffix **-C** or **-D**.

Example: Matching inner rings for bearing **SJ 7355** (2" x 2 9/16" x 1 1/4"):  
 a) **IR 7355 D** (1 5/8"ID x 2"OD x 1 1/4"W)  
 or  
 b) **IR 7355** (1 11/16"ID x 2"OD x 1 1/4"W)  
**Inner rings must be ordered separately.**

# Precision Ground Heavy Duty Needle Roller Bearings with Inner Rings



For matching inner rings see [page 11](#)

	Limit Speed (rpm)	Recommended Shaft Diameter				Recommended Housing Bore						MS 51961 Suffix	BEARING PART NUMBER
		ISO h6, use with H7 hsg fit		ISO f6, use with N7 hsg fit		Slip Fit ISO H7			Press Fit ISO N7				
		Max.	Min.	Max.	Min.	Min.	Max.	Mean Fit	Min.	Max.	Mean Fit		
	7,900	1.6875	1.6869	1.6865	1.6859	2.2500	2.2512	.0009L	2.2485	2.2496	.0006T		<b>SJ 7304</b>
	7,900	1.6875	1.6869	1.6865	1.6859	2.2500	2.2512	.0009L	2.2485	2.2496	.0006T	-26	<b>SJ 7305</b>
	7,600	1.7500	1.7494	1.7490	1.7484	2.3125	2.3137	.0009L	2.3110	2.3121	.0006T	-27	<b>SJ 7314*</b>
	7,600	1.7500	1.7494	1.7490	1.7484	2.3125	2.3137	.0009L	2.3110	2.3121	.0006T	-28	<b>SJ 7315*</b>
	7,400	1.8125	1.8119	1.8115	1.8109	2.3750	2.3762	.0009L	2.3735	2.3746	.0006T		<b>SJ 7324</b>
	7,400	1.8125	1.8119	1.8115	1.8109	2.3750	3.3762	.0009L	2.3735	2.3746	.0006T		<b>SJ 7325</b>
	7,100	1.8750	1.8744	1.8740	1.8734	2.4375	2.4387	.0009L	2.4360	2.4371	.0006T		<b>SJ 7334*</b>
	7,100	1.8750	1.8744	1.8740	1.8734	2.4375	2.4387	.0009L	2.4360	2.4371	.0006T	-29	<b>SJ 7335*</b>
	6,900	1.9375	1.9369	1.9365	1.9359	2.5000	2.5012	.0009L	2.4985	2.4996	.0006T		<b>SJ 7344</b>
	6,900	1.9375	1.9369	1.9365	1.9359	2.5000	2.5012	.0009L	2.4985	2.4996	.0006T		<b>SJ 7345</b>
	6,700	2.0000	1.9993	1.9988	1.9981	2.5625	2.5637	.0009L	2.5610	2.5621	.0006T		<b>SJ 7354*</b>
	6,700	2.0000	1.9993	1.9988	1.9981	2.5625	2.5637	.0009L	2.5610	2.5621	.0006T	-30	<b>SJ 7355*</b>
	5,900	2.2500	2.2493	2.2488	2.2481	3.0000	3.0012	.0009L	2.9985	2.9996	.0006T	-31	<b>SJ 8406</b>
	5,900	2.2500	2.2493	2.2488	2.2481	3.0000	3.0012	.0009L	2.9985	2.9996	.0006T	-32	<b>SJ 8407</b>
	5,300	2.5000	2.4993	2.4988	2.4981	3.2500	3.2514	.0011L	3.2482	3.2496	.0006T	-33	<b>SJ 8446</b>
	5,300	2.5000	2.4993	2.4988	2.4981	3.2500	3.2514	.0011L	3.2482	3.2496	.0006T	-34	<b>SJ 8447</b>
	4,800	2.7500	2.7493	2.7488	2.7481	3.5000	3.5014	.0011L	3.4982	3.4996	.0007T	-35	<b>SJ 8476</b>
	4,800	2.7500	2.7493	2.7488	2.7481	3.5000	3.5014	.0011L	3.4982	3.4996	.0007T	-36	<b>SJ 8477</b>
	4,500	3.0000	2.9993	2.9988	2.9981	3.7500	3.7514	.0011L	3.7482	3.7496	.0007T	-37	<b>SJ 8516</b>
	4,500	3.0000	2.9993	2.9988	2.9981	3.7500	3.7514	.0011L	3.7482	3.7496	.0007T	-38	<b>SJ 8517</b>
	4,300	3.1250	3.1243	3.1238	3.1231	4.0000	4.0014	.0011L	3.9982	3.9996	.0007T		<b>SJ 8536</b>
	4,300	3.1250	3.1243	3.1238	3.1231	4.0000	4.0014	.0011L	3.9982	3.9996	.0007T		<b>SJ 8537</b>
	4,100	3.2500	3.2491	3.2486	3.2477	4.2500	4.2514	.0011L	4.2482	4.2496	.0007T	-39	<b>SJ 9567</b>
	4,100	3.2500	3.2491	3.2486	3.2477	4.2500	4.2514	.0011L	4.2482	4.2496	.0007T	-40	<b>SJ 9568</b>

These bearings meet Military Standard MS 51961.

\* These bearings have a radius at both ends of the outer ring.

All other RBC outer rings are manufactured with a radius at one end and a break corner at the other.

# Precision Ground Heavy Duty Needle Roller Bearings

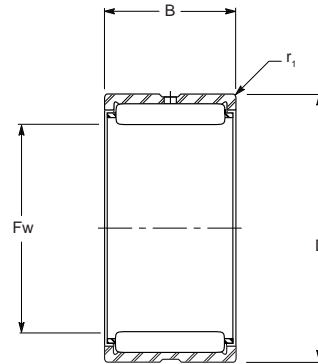

BEARING PART NUMBER	Fw Inside Diameter			D Outside Diameter		B Width +.000 -.005	r <sub>1</sub> Housing Fillet Max.	Approx. Weight (lbs.)	Housing Shoulder Dia. +/- 1/64"	Dynamic Capacity C (lbs.)	Static Capacity C <sub>0</sub> (lbs.)
	Nominal	Min.	Max.	Max.	Min.						
SJ 9607	3 1/2	3.5012	3.5024	4.5000	4.4992	1.750	.10	2.47	3 15/16	24,400	59,600
SJ 9608	3 1/2	3.5012	3.5024	4.5000	4.4992	2.000	.10	2.82	3 15/16	27,900	70,900
SJ 9648	3 3/4	3.7512	3.7524	4.7500	4.7492	2.000	.10	3.00	4 3/16	27,700	71,300
SJ 9687	4	4.0012	4.0024	5.0000	4.9990	1.750	.10	2.79	4 7/16	25,700	66,900
SJ 9688	4	4.0012	4.0024	5.0000	4.9990	2.000	.10	3.19	4 7/16	29,400	79,600
SJ 9717	4 1/8	4.1262	4.1274	5.1250	5.1240	1.750	.10	2.84	4 9/16	26,400	69,300
SJ 9718	4 1/8	4.1262	4.1274	5.1250	5.1240	2.000	.10	3.25	4 9/16	30,200	82,400
SJ 9728	4 1/4	4.2512	4.2526	5.2500	5.2490	2.000	.10	3.35	4 11/16	30,600	85,200
SJ 6768	4 1/2	4.5012	4.5026	6.0000	5.9990	2.000	.12	5.40	5 1/8	37,700	82,900
SJ 6769	4 1/2	4.5012	4.5026	6.0000	5.9990	2.250	.12	6.08	5 1/8	42,800	97,600
SJ 6770	4 1/2	4.5012	4.5026	6.0000	5.9990	2.500	.12	6.75	5 1/8	47,800	112,000
SJ 6848	5	5.0013	5.0027	6.5000	6.4990	2.000	.12	5.91	5 5/8	40,700	94,500
SJ 6849	5	5.0013	5.0027	6.5000	6.4990	2.250	.12	6.65	5 5/8	46,200	111,000
SJ 6850	5	5.0013	5.0027	6.5000	6.4990	2.500	.12	7.38	5 5/8	51,500	128,000
SJ 6918	5 1/2	5.5013	5.5027	7.0000	6.9990	2.500	.12	8.00	6 1/8	53,600	139,000
SJ 6919	5 1/2	5.5013	5.5027	7.0000	6.9990	3.000	.12	9.60	6 1/8	64,200	175,000
SJ 6925	6	6.0013	6.0027	7.5000	7.4988	2.500	.12	8.62	6 5/8	55,500	150,000
SJ 6926	6	6.0013	6.0027	7.5000	7.4988	3.000	.12	10.37	6 5/8	66,500	189,000
SJ 6935	6 1/2	6.5013	6.5029	8.0000	7.9988	2.500	.12	9.55	7 1/8	58,600	166,000
SJ 6936	6 1/2	6.5013	6.5029	8.0000	7.9988	3.000	.12	11.48	7 1/8	70,200	209,000
SJ 2325	7 1/4	7.2514	7.2530	9.1250	9.1238	2.500	.14	13.11	8 1/8	64,400	162,000
SJ 2326	7 1/4	7.2514	7.2530	9.1250	9.1238	3.000	.14	15.75	8 1/8	78,500	209,000
SJ 2425	7 3/4	7.7514	7.7530	9.6250	9.6238	2.500	.14	14.20	8 5/8	67,600	175,500
SJ 2426	7 3/4	7.7514	7.7530	9.6250	9.6238	3.000	.14	17.05	8 5/8	82,000	225,000
SJ 2526	8 1/4	8.2514	8.2532	10.1250	10.1238	3.000	.14	18.41	9 1/8	85,300	241,000
SJ 2625	8 3/4	8.7514	8.7532	10.6250	10.6236	2.500	.14	16.45	9 5/8	72,000	199,000
SJ 2626	8 3/4	8.7514	8.7532	10.6250	10.6236	3.000	.14	19.75	9 5/8	87,800	257,000
SJ 2726	9 1/4	9.2514	9.2532	11.1250	11.1236	3.000	.14	21.07	10 1/8	90,800	273,000
SJ 2926	10 1/4	10.2515	10.2533	12.1250	12.1236	3.000	.14	23.05	11 1/8	96,500	305,000

All dimensions in inches.

For matching inner rings see **page 12**

The part numbers of matching inner rings are the same as the corresponding bearing numbers, except that the prefix **SJ** is replaced by the prefix **IR**.

Alternate inner rings with different inside diameters are available for several bearings.

Alternate inner rings carry the suffix **-C** or **-D**.

Example: Matching inner rings for bearing **SJ 9688** ( 4" x 5" x 2") are:

- a) **IR 9688 D** ( 3 1/4"ID x 4"OD x 2"W)
- or
- b) **IR 9688** ( 3 3/8"ID x 4"OD x 2"W)
- c) **IR 9688 C** ( 3 1/2"ID x 4"OD x 2"W)

**Inner rings must be ordered separately.**



# Precision Ground Heavy Duty Needle Roller Bearings with Inner Rings



For matching inner rings see [page 12](#)

Limit Speed (rpm)	Recommended Shaft Diameter				Recommended Housing Bore						MS 51961 Suffix	BEARING PART NUMBER
	ISO h6, use with H7 hsg fit		ISO f6, use with N7 hsg fit		Slip Fit ISO H7			Press Fit ISO N7				
	Max.	Min.	Max.	Min.	Min.	Max.	Mean Fit	Min.	Max.	Mean Fit		
3,800	3.5000	3.4991	3.4986	3.4977	4.5000	4.5014	.0011L	4.4982	4.4996	.0007T	-41	<b>SJ 9607</b>
3,800	3.5000	3.4991	3.4986	3.4977	4.5000	4.5014	.0011L	4.4982	4.4996	.0007T	-42	<b>SJ 9608</b>
3,600	3.7500	3.7491	3.7486	3.7477	4.7500	4.7516	.0012L	4.7480	4.7495	.0007T	-43	<b>SJ 9648</b>
3,300	4.0000	3.9991	3.9986	3.9977	5.0000	5.0016	.0013L	4.9980	4.9995	.0009T	-44	<b>SJ 9687</b>
3,300	4.0000	3.9991	3.9986	3.9977	5.0000	5.0016	.0013L	4.9980	4.9995	.0009T	-45	<b>SJ 9688</b>
3,200	4.1250	4.1241	4.1236	4.1227	5.1250	5.1266	.0013L	5.1230	5.1245	.0009T		<b>SJ 9717</b>
3,200	4.1250	4.1241	4.1236	4.1227	5.1250	5.1266	.0013L	5.1230	5.1245	.0009T		<b>SJ 9718</b>
3,100	4.2500	4.2491	4.2486	4.2477	5.2500	5.2516	.0013L	5.2480	5.2495	.0009T	-46	<b>SJ 9728</b>
3,000	4.5000	4.4991	4.4986	4.4977	6.0000	6.0016	.0013L	5.9980	5.9995	.0009T	-47	<b>SJ 6768</b>
3,000	4.5000	4.4991	4.4986	4.4977	6.0000	6.0016	.0013L	5.9980	5.9995	.0009T	-48	<b>SJ 6769</b>
3,000	4.5000	4.4991	4.4986	4.4977	6.0000	6.0016	.0013L	5.9980	5.9995	.0009T	-49	<b>SJ 6770</b>
2,700	5.0000	4.9990	4.9983	4.9973	6.5000	6.5016	.0013L	6.4980	6.4995	.0009T	-50	<b>SJ 6848</b>
2,700	5.0000	4.9990	4.9983	4.9973	6.5000	6.5016	.0013L	6.4980	6.4995	.0009T		<b>SJ 6849</b>
2,680	5.0000	4.9990	4.9983	4.9973	6.5000	6.5016	.0013L	6.4980	6.4995	.0009T	-51	<b>SJ 6850</b>
2,400	5.5000	5.4990	5.4983	5.4973	7.0000	7.0016	.0013L	6.9980	6.9995	.0009T	-52	<b>SJ 6918</b>
2,400	5.5000	5.4990	5.4983	5.4973	7.0000	7.0016	.0013L	6.9980	6.9995	.0009T	-53	<b>SJ 6919</b>
2,200	6.0000	5.9990	5.9983	5.9973	7.5000	7.5018	.0015L	7.4976	7.4994	.0011T	-55	<b>SJ 6925</b>
2,200	6.0000	5.9990	5.9983	5.9973	7.5000	7.5018	.0015L	7.4976	7.4994	.0011T	-56	<b>SJ 6926</b>
2,000	6.5000	6.4990	6.4983	6.4973	8.0000	8.0018	.0015L	7.9976	7.9994	.0011T	-57	<b>SJ 6935</b>
2,000	6.5000	6.4990	6.4983	6.4973	8.0000	8.0018	.0015L	7.9976	7.9994	.0011T	-58	<b>SJ 6936</b>
1,800	7.2500	7.2489	7.2480	7.2469	9.1250	9.1268	.0015L	9.1226	9.1244	.0011T		<b>SJ 2325</b>
1,800	7.2500	7.2489	7.2480	7.2469	9.1250	9.1268	.0015L	9.1226	9.1244	.0011T	-59	<b>SJ 2326</b>
1,700	7.7500	7.7489	7.7480	7.7469	9.6250	9.6268	.0015L	9.6226	9.6244	.0011T		<b>SJ 2425</b>
1,700	7.7500	7.7489	7.7480	7.7469	9.6250	9.6268	.0015L	9.6226	9.6244	.0011T		<b>SJ 2426</b>
1,600	8.2500	8.2489	8.2480	8.2469	10.1250	10.1270	.0016L	10.1224	10.1244	.0011T		<b>SJ 2526</b>
1,500	8.7500	8.7489	8.7480	8.7469	10.6250	10.6270	.0017L	10.6224	10.6244	.0011T		<b>SJ 2625</b>
1,500	8.7500	8.7489	8.7480	8.7469	10.6250	10.6270	.0017L	10.6224	10.6244	.0011T		<b>SJ 2626</b>
1,400	9.2500	9.2489	9.2480	9.2469	11.1250	11.1270	.0017L	11.1224	11.1244	.0011T		<b>SJ 2726</b>
1,300	10.2500	10.2487	10.2478	10.2465	12.1250	12.1270	.0017L	12.1224	12.1244	.0011T		<b>SJ 2926</b>

These bearings meet Military Standard MS 51961.

# Precision Ground Heavy Duty Needle Roller Bearings with Seals

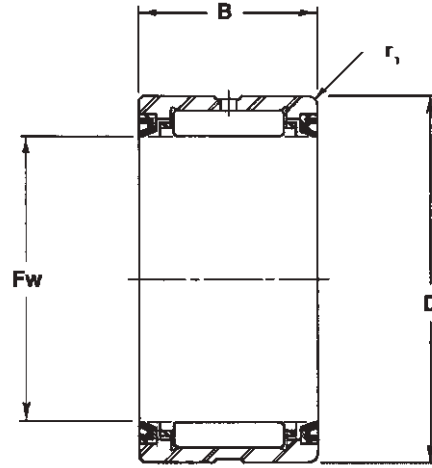

BEARING PART NUMBER	Fw Inside Diameter			D Outside Diameter		B Width +.000 -.005	r <sub>1</sub> Housing Fillet Max.	Approx. Weight (lbs.)	Housing Shoulder Dia. +/- 1/64"	Dynamic Capacity C (lbs.)	Static Capacity C <sub>0</sub> (lbs.)
	Nominal	Min.	Max.	Max.	Min.						
SJ 7134 SS	5/8	.6258	.6267	1.1250	1.1245	1.000	.04	.156	15/16	3,200	4,000
SJ 7154 SS	3/4	.7509	.7518	1.2500	1.2495	1.000	.04	.171	1 1/16	4,500	6,000
SJ 7174 SS	7/8	.8759	.8768	1.3750	1.3745	1.000	.04	.187	1 3/16	4,700	6,700
SJ 7194 SS	1	1.0009	1.0018	1.5000	1.4995	1.000	.04	.218	1 5/16	5,200	7,900
SJ 7215 SS	1 1/8	1.1259	1.1268	1.6250	1.6245	1.250	.04	.282	1 3/8	7,600	13,200
SJ 7235 SS	1 1/4	1.2510	1.2519	1.7500	1.7495	1.250	.04	.380	1 9/16	7,900	14,200
SJ 7255 SS	1 3/8	1.3760	1.3769	1.8750	1.8745	1.250	.04	.410	1 11/16	8,400	15,900
SJ 7275 SS	1 1/2	1.5010	1.5019	2.0625	2.0619	1.250	.06	.438	1 13/16	8,100	16,000
SJ 7295 SS	1 5/8	1.6260	1.6269	2.1875	2.1869	1.250	.06	.468	1 15/16	10,000	19,500
SJ 7315 SS	1 3/4	1.7510	1.7520	2.3125	2.3119	1.250	.06	.500	2 1/16	9,900	19,700
SJ 7335 SS	1 7/8	1.8760	1.8770	2.4375	2.4369	1.250	.06	.527	2 3/16	10,400	21,500
SJ 7355 SS	2	2.0011	2.0021	2.5625	2.5619	1.250	.06	.562	2 1/16	10,700	22,500
SJ 8407 SS	2 1/4	2.2511	2.2521	3.0000	2.9994	1.750	.08	1.25	2 5/8	15,100	33,200
SJ 8447 SS	2 1/2	2.5011	2.5021	3.2500	3.2494	1.750	.08	1.38	2 7/8	15,800	36,400
SJ 8477 SS	2 3/4	2.7511	2.7521	3.5000	3.4992	1.750	.08	1.46	3 1/8	16,300	39,600
SJ 8517 SS	3	3.0011	3.0023	3.7500	3.7492	1.750	.08	1.57	3 3/8	17,600	44,200
SJ 9568 SS	3 1/4	3.2512	3.2524	4.2500	4.2492	2.000	.10	2.69	3 11/16	23,500	55,100
SJ 9608 SS	3 1/2	3.5012	3.5024	4.5000	4.4992	2.000	.10	2.82	3 15/16	24,200	59,900
SJ 9648 SS	3 3/4	3.7512	3.7524	4.7500	4.7492	2.000	.10	3.00	4 3/16	25,600	64,600
SJ 9688 SS	4	4.0012	4.0024	5.0000	4.9990	2.000	.10	3.19	4 7/16	26,200	67,200
SJ 9718 SS	4 1/8	4.1262	4.1274	5.1250	5.1240	2.000	.10	3.25	4 9/16	26,000	69,500

All dimensions in inches.

For matching inner rings see **pages 10-12**.

The numeric portion of a suitable inner ring part number matches the numeric component of the bearing. Inner rings with suffix **-C** or **-D** differ in inside diameter.

Example: Suitable inner rings for bearing **SJ 8447 SS** ( 2 1/2" x 3 1/4" x 1 3/4" ) are:

- a) **IR 8447** ( 1 15/16"ID x 2 1/2"OD x 1 3/4"W )  
or
- b) **IR 8447 C** ( 2"ID x 2 1/2"OD x 1 3/4"W )  
or
- c) **IR 8447 C1** ( 2 1/8"ID x 2 1/2"OD x 1 3/4"W ).

**Inner rings must be ordered separately.**

# Available Seal Configurations



**TYPE—S**

Single seal mounted in radius end of ring with sealing lip turned outward to exclude dirt.  
Bearing # SJ — S

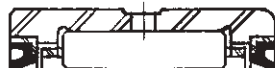

**TYPE—SS**

Double seal with sealing lips turned outward to exclude dirt.  
Bearing # SJ — SS



**TYPE—SR**

Double seal with one seal mounted in chamfered end with sealing lip turned outward to exclude dirt and one seal mounted in radius end with sealing lip turned inward to retain lubricant.  
Bearing # SJ — SR



**TYPE—SX**

Single seal mounted in chamfered end of ring with sealing lip turned outward to exclude dirt.  
Bearing # SJ — SX

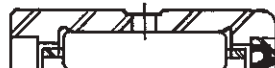

**TYPE—R**

Single seal mounted in radius end of ring with sealing lip turned inward to retain lubricant.  
Bearing # SJ — R

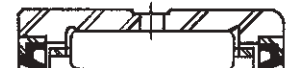

**TYPE—RR**

Double seal with sealing lips turned inward to retain lubricant.  
Bearing # SJ — RR



**TYPE—RS**

Double seal with one seal mounted in chamfered end with sealing lip turned inward to retain lubricant and one seal mounted in radius end with sealing lip turned outward to exclude dirt.



**TYPE—RX**

Single seal mounted in chamfered end of ring with sealing lip turned inward to retain lubricant.  
Bearing # SJ — RX

**CAUTION**

1. When assembling shaft against the sealing lip, the shaft end must be chamfered.
2. For effective sealing the shaft must have a finish of 20 micro inches maximum.
3. These seals are suitable for shaft speeds of 1,000 feet per minute—higher speeds are possible but seal life is shortened.
4. This type of seal is suitable for a continuous operating temperature of 250° F. However, they will operate under intermittent temperatures of up to 300° F.
5. When ordering, be sure to designate how the seal is to be mounted by using the correct suffix—unless specified otherwise, type "SS" will be shipped.

Limit Speed (rpm)	Recommended Shaft Diameter				Recommended Housing Bore						BEARING PART NUMBER
	ISO h6, use with H7 hsg fit		ISO f6, use with N7 hsg fit		Slip Fit ISO H7			Press Fit ISO N7			
	Max.	Min.	Max.	Min.	Min.	Max.	Mean Fit	Min.	Max.	Mean Fit	
6,100	.6250	.6246	.6244	.6239	1.1250	1.1258	.0006L	1.1239	1.1247	.0004T	<b>SJ 7134 SS</b>
5,100	.7500	.7495	.7492	.7487	1.2500	1.2510	.0007L	1.2487	1.2497	.0005T	<b>SJ 7154 SS</b>
4,400	.8750	.8745	.8742	.8737	1.3750	1.3760	.0007L	1.3737	1.3747	.0005T	<b>SJ 7174 SS</b>
3,800	1.0000	.9995	.9992	.9987	1.5000	1.5010	.0007L	1.4987	1.4997	.0005T	<b>SJ 7194 SS</b>
3,400	1.1250	1.1245	1.1242	1.1237	1.6250	1.6260	.0007L	1.6237	1.6247	.0005T	<b>SJ 7215 SS</b>
3,100	1.2500	1.2494	1.2490	1.2484	1.7500	1.7510	.0007L	1.7487	1.7497	.0005T	<b>SJ 7235 SS</b>
2,800	1.3750	1.3744	1.3740	1.3734	1.8750	1.8760	.0007L	1.8737	1.8747	.0005T	<b>SJ 7255 SS</b>
2,500	1.5000	1.4994	1.4990	1.4984	2.0625	2.0637	.0009L	2.0610	2.0621	.0006T	<b>SJ 7275 SS</b>
2,400	1.6250	1.6244	1.6240	1.6234	2.1875	2.1887	.0009L	2.1860	2.1871	.0006T	<b>SJ 7295 SS</b>
2,200	1.7500	1.7494	1.7490	1.7484	2.3125	2.3137	.0009L	2.3110	2.3121	.0006T	<b>SJ 7315 SS</b>
2,000	1.8750	1.8744	1.8740	1.8734	2.4375	2.4387	.0009L	2.4360	2.4371	.0006T	<b>SJ 7335 SS</b>
1,900	2.0000	1.9993	1.9988	1.9981	2.5625	2.5637	.0009L	2.5610	2.5621	.0006T	<b>SJ 7355 SS</b>
1,700	2.2500	2.2493	2.2488	2.2481	3.0000	3.0012	.0009L	2.9985	2.9996	.0006T	<b>SJ 8407 SS</b>
1,500	2.5000	2.4993	2.4988	2.4981	3.2500	3.2514	.0010L	3.2482	3.2496	.0006T	<b>SJ 8447 SS</b>
1,400	2.7500	2.7493	2.7488	2.7481	3.5000	3.5014	.0011L	3.4982	3.4996	.0007T	<b>SJ 8477 SS</b>
1,300	3.0000	2.9993	2.9988	2.9981	3.7500	3.7514	.0011L	3.7482	3.7496	.0007T	<b>SJ 8517 SS</b>
1,200	3.2500	3.2491	3.2486	3.2477	4.2500	4.2514	.0011L	4.2482	4.2496	.0007T	<b>SJ 9568 SS</b>
1,100	3.5000	3.4991	3.4986	3.4977	4.5000	4.5014	.0011L	4.4982	4.4996	.0007T	<b>SJ 9608 SS</b>
1,000	3.7500	3.7491	3.7486	3.7477	4.7500	4.7516	.0012L	4.7480	4.7495	.0008T	<b>SJ 9648 SS</b>
950	4.0000	3.9991	3.9986	3.9977	5.0000	5.0016	.0013L	4.9980	4.9995	.0008T	<b>SJ 9688 SS</b>
950	4.1250	4.1241	4.1236	4.1227	5.1250	5.1266	.0013L	5.1230	5.1245	.0008T	<b>SJ 9718 SS</b>

Outer rings have a radius on one end and a break corner at the opposite end.

# Inner Rings

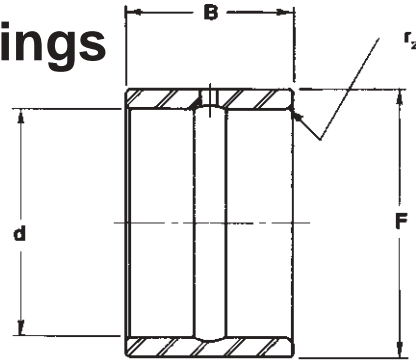

INNER RING PART NUMBER	d Inside Diameter			F Outside Diameter			B Width +.000 -.005	r <sub>2</sub> Shaft Fillet Max.	Approx. Weight (lbs)	RECOMMENDED SHAFT DIAMETER				MS 51962 suffix
	Nominal 1)	Min.	Max.	Nominal 1)	Max.	Min.				Slip Fit ISO g6		Press Fit ISO m5		
										Max.	Min.	Max.	Min.	
IR 7133	3/8	.3746	.3750	5/8	.6245	.6241	.760	.04	.042	.3748	.3744	.3755	.3752	-1
IR 7134	3/8	.3746	.3750	5/8	.6245	.6241	1.010	.04	.055	.3748	.3744	.3755	.3752	
IR 7153	1/2	.4996	.5000	3/4	.7493	.7488	.760	.04	.050	.4997	.4993	.5006	.5003	-2
IR 7154	1/2	.4996	.5000	3/4	.7493	.7488	1.010	.04	.067	.4997	.4993	.5006	.5003	-3
IR 7153 C	9/16	.5621	.5625	3/4	.7493	.7488	.760	.04	.041	.5622	.5618	.5631	.5628	
IR 7154 C	9/16	.5621	.5625	3/4	.7493	.7488	1.010	.04	.055	.5622	.5618	.5631	.5628	
IR 7173	5/8	.6246	.6250	7/8	.8743	.8738	.760	.04	.058	.6247	.6243	.6256	.6253	-4
IR 7174	5/8	.6246	.6250	7/8	.8743	.8738	1.010	.04	.077	.6247	.6243	.6256	.6253	
IR 7173 C	11/16	.6871	.6875	7/8	.8743	.8738	.760	.04	.049	.6872	.6868	.6881	.6878	
IR 7193	3/4	.7496	.7500	1	.9993	.9988	.760	.04	.065	.7497	.7492	.7507	.7503	-5
IR 7194	3/4	.7496	.7500	1	.9993	.9988	1.010	.04	.087	.7497	.7492	.7507	.7503	
IR 7193 C	13/16	.8120	.8125	1	.9993	.9988	.760	.04	.057	.8122	.8117	.8132	.8128	-6
IR 7194 C	13/16	.8120	.8125	1	.9993	.9988	1.010	.04	.076	.8122	.8117	.8132	.8128	-7
IR 7204	13/16	.8120	.8125	1 1/16	1.0618	1.0613	1.010	.04	.097	.8122	.8117	.8132	.8128	
IR 7205	13/16	.8120	.8125	1 1/16	1.0618	1.0613	1.260	.04	.121	.8122	.8117	.8132	.8128	
IR 7214	7/8	.8745	.8750	1 1/8	1.1241	1.1236	1.010	.04	.106	.8747	.8742	.8757	.8753	-8
IR 7215	7/8	.8745	.8750	1 1/8	1.1241	1.1236	1.260	.04	.132	.8747	.8742	.8757	.8753	
IR 7214 C	15/16	.9370	.9375	1 1/8	1.1241	1.1236	1.010	.04	.086	.9372	.9367	.9382	.9378	-9
IR 7215 C	15/16	.9370	.9375	1 1/8	1.1241	1.1236	1.260	.04	.108	.9372	.9367	.9382	.9378	
IR 7234	1	.9995	1.0000	1 1/4	1.2491	1.2485	1.010	.04	.126	.9997	.9992	1.0007	1.0003	-10
IR 7235	1	.9995	1.0000	1 1/4	1.2491	1.2485	1.260	.04	.157	.9997	.9992	1.0007	1.0003	-11
IR 7244	1 1/16	1.0620	1.0625	1 5/16	1.3116	1.3110	1.010	.04	.130	1.0622	1.0617	1.0632	1.0628	
IR 7245	1 1/16	1.0620	1.0625	1 5/16	1.3116	1.3110	1.260	.04	.163	1.0622	1.0617	1.0632	1.0628	
IR 7254 D	1	.9995	1.0000	1 3/8	1.3741	1.3735	1.010	.04	.178	.9997	.9992	1.0007	1.0003	
IR 7255 D	1 1/16	1.0620	1.0625	1 3/8	1.3741	1.3735	1.260	.04	.222	1.0622	1.0617	1.0632	1.0628	
IR 7254	1 1/8	1.1245	1.1250	1 3/8	1.3741	1.3735	1.010	.04	.135	1.1247	1.1242	1.1257	1.1253	-12
IR 7255	1 1/8	1.1245	1.1250	1 3/8	1.3741	1.3735	1.260	.04	.169	1.1247	1.1242	1.1257	1.1253	-13
IR 7274	1 3/16	1.1870	1.1875	1 1/2	1.4990	1.4984	1.010	.06	.184	1.1871	1.1865	1.1883	1.1879	
IR 7275	1 3/16	1.1870	1.1875	1 1/2	1.4990	1.4984	1.260	.06	.230	1.1871	1.1865	1.1883	1.1879	-14
IR 7274 C	1 1/4	1.2495	1.2500	1 1/2	1.4990	1.4984	1.010	.06	.086	1.2496	1.2490	1.2508	1.2504	-15
IR 7275 C	1 1/4	1.2495	1.2500	1 1/2	1.4990	1.4984	1.260	.06	.191	1.2496	1.2490	1.2508	1.2504	-16
IR 7284	1 1/4	1.2495	1.2500	1 9/16	1.5615	1.5609	1.010	.06	.184	1.2496	1.2490	1.2508	1.2504	
IR 7285	1 1/4	1.2495	1.2500	1 9/16	1.5615	1.5609	1.260	.06	.228	1.2496	1.2490	1.2508	1.2504	
IR 7295 D	1 1/4	1.2495	1.2500	1 5/8	1.6240	1.6234	1.260	.06	.299	1.2496	1.2490	1.2508	1.2504	
IR 7295	1 5/16	1.3120	1.3125	1 5/8	1.6240	1.6234	1.260	.06		1.3121	1.3115	1.3133	1.3129	
IR 7294	1 5/16	1.3120	1.3125	1 5/8	1.6240	1.6234	1.010	.06		1.3121	1.3115	1.3133	1.3129	
IR 7295 C	1 3/8	1.3745	1.3750	1 5/8	1.6240	1.6234	1.260	.06	.209	1.3746	1.3740	1.3758	1.3754	-18
IR 7304	1 3/8	1.3745	1.3750	1 11/16	1.6865	1.6859	1.010	.06	.212	1.3746	1.3740	1.3758	1.3754	
IR 7305	1 3/8	1.3745	1.3750	1 11/16	1.6865	1.6859	1.260	.06	.265	1.3746	1.3740	1.3758	1.3754	

All dimensions in inches

These inner rings meet Military Standard MS 51962

1) Sorted by outside diameter.



# Inner Rings

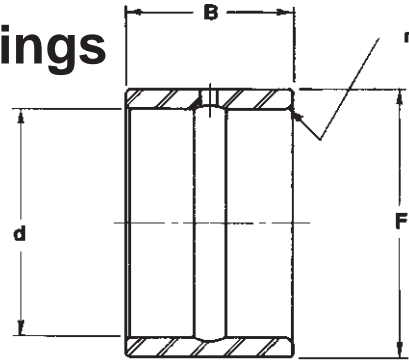

INNER RING PART NUMBER	d Inside Diameter			F Outside Diameter			B Width +.000 -.005	r <sub>2</sub> Shaft Fillet Max.	Approx. Weight (lbs)	RECOMMENDED SHAFT DIAMETER				MS 51962 suffix
	Nominal 1)	Min.	Max.	Nominal 1)	Max.	Min.				Slip Fit ISO g6		Press Fit ISO m5		
										Max.	Min.	Max.	Min.	
IR 7315 D	1 3/8	1.3745	1.3750	1 3/4	1.7490	1.7484	1.260	.06	.328	1.3746	1.3740	1.3758	1.3754	-19
IR 7314	1 7/16	1.4370	1.4375	1 3/4	1.7490	1.7484	1.010	.06	.223	1.4371	1.4365	1.4383	1.4379	
IR 7315	1 7/16	1.4370	1.4375	1 3/4	1.7490	1.7484	1.260	.06	.278	1.4371	1.4365	1.4383	1.4379	-20
IR 7314 C	1 1/2	1.4995	1.5000	1 3/4	1.7490	1.7484	1.010	.06	.182	1.4996	1.4990	1.5008	1.5004	-21
IR 7315 C	1 1/2	1.4995	1.5000	1 3/4	1.7490	1.7484	1.260	.06	.227	1.4996	1.4990	1.5008	1.5004	-22
IR 7324	1 1/2	1.4995	1.5000	1 13/16	1.8115	1.8109	1.010	.06	.232	1.4996	1.4990	1.5008	1.5004	
IR 7325	1 1/2	1.4995	1.5000	1 13/16	1.8115	1.8109	1.260	.06	.289	1.4996	1.4990	1.5008	1.5004	
IR 7334	1 9/16	1.5620	1.5625	1 7/8	1.8740	1.8734	1.010	.06	.240	1.5621	1.5615	1.5633	1.5629	
IR 7335	1 9/16	1.5620	1.5625	1 7/8	1.8740	1.8734	1.260	.06	.300	1.5621	1.5615	1.5633	1.5629	
IR 7344	1 5/8	1.6245	1.6250	1 15/16	1.9364	1.9357	1.010	.06	.249	1.6246	1.6240	1.6258	1.6254	
IR 7345	1 5/8	1.6245	1.6250	1 15/16	1.9364	1.9357	1.260	.06	.311	1.6246	1.6240	1.6258	1.6254	
IR 7355 D2	1 1/2	1.4995	1.5000	2	1.9989	1.9982	1.260	.06	.490	1.4996	1.4990	1.5008	1.5004	
IR 7355 D1	1 9/16	1.5620	1.5625	2	1.9989	1.9982	1.260	.06	.436	1.5621	1.5615	1.5633	1.5629	
IR 7355D	1 5/8	1.6245	1.6250	2	1.9989	1.9982	1.260	.06	.380	1.6246	1.6240	1.6258	1.6254	-23
IR 7354	1 11/16	1.6870	1.6875	2	1.9989	1.9982	1.010	.06	.258	1.6871	1.6865	1.6883	1.6879	
IR 7355	1 11/16	1.6870	1.6875	2	1.9989	1.9982	1.260	.06	.322	1.6871	1.6865	1.6883	1.6879	
IR 8406	1 3/4	1.7495	1.7500	2 1/4	2.2489	2.2482	1.510	.06	.670	1.7496	1.7490	1.7508	1.7504	-24
IR 8407	1 3/4	1.7495	1.7500	2 1/4	2.2489	2.2482	1.760	.06	.781	1.7496	1.7490	1.7508	1.7504	-25
IR 8407 C1	1 7/8	1.8745	1.8750	2 1/4	2.2489	2.2482	1.760	.06	.604	1.8746	1.8740	1.8758	1.8754	
IR 8446	1 15/16	1.9370	1.9375	2 1/2	2.4989	2.4982	1.510	.08	.837	1.9371	1.9365	1.9383	1.9379	
IR 8447	1 15/16	1.9370	1.9375	2 1/2	2.4989	2.4982	1.760	.08	.975	1.9371	1.9365	1.9383	1.9379	-26
IR 8446 C	2	1.9995	2.0000	2 1/2	2.4989	2.4982	1.510	.08	.754	1.9996	1.9989	2.0010	2.0005	-27
IR 8447 C	2	1.9995	2.0000	2 1/2	2.4989	2.4982	1.760	.08	.879	1.9996	1.9989	2.0010	2.0005	
IR 8447 C1	2 1/8	2.1244	2.1250	2 1/2	2.4989	2.4982	1.760	.08	.677	2.1246	2.1239	2.1260	2.1255	
IR 8476	2 3/16	2.1869	2.1875	2 3/4	2.7489	2.7482	1.510	.08	.931	2.1871	2.1864	2.1885	2.1880	
IR 8477	2 3/16	2.1869	2.1875	2 3/4	2.7489	2.7482	1.760	.08	1.085	2.1871	2.1864	2.1885	2.1880	-28
IR 8476 C	2 1/4	2.2494	2.2500	2 3/4	2.7489	2.7482	1.510	.08	.838	2.2496	2.2489	2.2510	2.2505	-29
IR 8477 C	2 1/4	2.2494	2.2500	2 3/4	2.7489	2.7482	1.760	.08	.976	2.2496	2.2489	2.2510	2.2505	
IR 8516	2 3/8	2.3744	2.3750	3	2.9989	2.9982	1.510	.08	1.126	2.3746	2.3739	2.3760	2.3755	
IR 8517	2 3/8	2.3744	2.3750	3	2.9989	2.9982	1.760	.08	1.313	2.3746	2.3739	2.3760	2.3755	-30
IR 8516 C	2 1/2	2.4994	2.5000	3	2.9989	2.9982	1.510	.08	.922	2.4996	2.4989	2.5010	2.5005	-31
IR 8517 C	2 1/2	2.4994	2.5000	3	2.9989	2.9982	1.760	.08	1.074	2.4996	2.4989	2.5010	2.5005	
IR 8536	2 1/2	2.4994	2.5000	3 1/8	3.1237	3.1228	1.510	.08	1.178	2.4996	2.4989	2.5010	2.5005	
IR 8537	2 1/2	2.4994	2.5000	3 1/8	3.1237	3.1228	1.760	.08	1.373	2.4996	2.4989	2.5010	2.5005	
IR 9567 D	2 5/8	2.6244	2.6250	3 1/4	3.2487	3.2478	1.760	.08	1.434	2.6246	2.6239	2.6260	2.6255	
IR 9567	2 3/4	2.7494	2.7500	3 1/4	3.2487	3.2478	1.760	.08	1.171	2.7496	2.7489	2.7510	2.7505	-32
IR 9568	2 3/4	2.7494	2.7500	3 1/4	3.2487	3.2478	2.010	.08	1.337	2.7496	2.7489	2.7510	2.7505	-33

All dimensions in inches

These inner rings meet Military Standard MS 51962

1) Sorted by outside diameter.

# Inner Rings

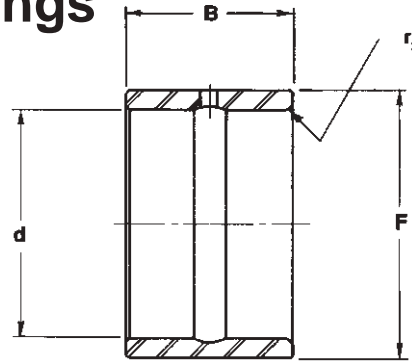

INNER RING PART NUMBER	d Inside Diameter			F Outside Diameter			B Width +.000 -.005	r <sub>2</sub> Shaft Fillet Max.	Approx. Weight (lbs)	RECOMMENDED SHAFT DIAMETER				MS 51962 suffix
	Nominal 1)	Min.	Max.	Nominal 1)	Max.	Min.				Slip Fit ISO g6		Press Fit ISO m5		
										Max.	Min.	Max.	Min.	
IR 9607	2 15/16	2.9369	2.9375	3 1/2	3.4987	3.4978	1.760	.08	1.41	2.9371	2.9364	2.9384	2.9379	
IR 9608	2 15/16	2.9369	2.9375	3 1/2	3.4987	3.4978	2.010	.08	1.61	2.9371	2.9364	2.9384	2.9379	-34
IR 9608 C	3	2.9994	3.0000	3 1/2	3.4987	3.4978	2.010	.08	1.44	2.9996	2.9989	3.0009	3.0004	
IR 9647	3 1/8	3.1244	3.1250	3 3/4	3.7487	3.7478	1.760	.10	1.67	3.1246	3.1239	3.1259	3.1254	
IR 9648	3 1/8	3.1244	3.1250	3 3/4	3.7487	3.7478	2.010	.10	1.91	3.1246	3.1239	3.1259	3.1254	-35
IR 9648 C	3 1/4	3.2494	3.2500	3 3/4	3.7487	3.7478	2.010	.10	1.55	3.2495	3.2487	3.2511	3.2505	-36
IR 9687	3 3/8	3.3742	3.3750	4	3.9985	3.9976	1.760	.10	1.79	3.3745	3.3737	3.3761	3.3755	
IR 9688 D	3 1/4	3.2494	3.2500	4	3.9985	3.9976	2.010	.10	2.42	3.2495	3.2487	3.2511	3.2505	-37
IR 9688	3 3/8	3.3742	3.3750	4	3.9985	3.9976	2.010	.10	2.05	3.3745	3.3737	3.3761	3.3755	-38
IR 9688 C	3 1/2	3.4992	3.5000	4	3.9985	3.9976	2.010	.10	1.66	3.4995	3.4987	3.5011	3.5005	
IR 9717	3 1/2	3.4992	3.5000	4 1/8	4.1235	4.1226	1.760	.10	1.85	3.4995	3.4987	3.5011	3.5005	
IR 9718	3 1/2	3.4992	3.5000	4 1/8	4.1235	4.1226	2.010	.10	2.12	3.4995	3.4987	3.5011	3.5005	
IR 9728	3 1/2	3.4992	3.5000	4 1/4	4.2485	4.2476	2.010	.10	2.58	3.4995	3.4987	3.5011	3.5005	-39
IR 9728 C1	3 3/4	3.7492	3.7500	4 1/4	4.2485	4.2476	2.010	.10	1.78	3.7495	3.7487	3.7511	3.7505	-40
IR 6768	3 3/4	3.7492	3.7500	4 1/2	4.4985	4.4976	2.010	.10	2.75	3.7495	3.7487	3.7511	3.7505	
IR 6769	3 3/4	3.7492	3.7500	4 1/2	4.4985	4.4976	2.260	.10	3.09	3.7495	3.7487	3.7511	3.7505	
IR 6769 C	3 7/8	3.8742	3.8750	4 1/2	4.4985	4.4976	2.260	.10	2.62	3.8745	3.8737	3.8761	3.8755	
IR 6770	3 3/4	3.7492	3.7500	4 1/2	4.4985	4.4976	2.515	.10	3.44	3.7495	3.7487	3.7511	3.7505	-41
IR 6848	4	3.9992	4.0000	5	4.9985	4.9975	2.010	.10	4.00	3.9995	3.9987	4.0011	4.0005	
IR 6849	4	3.9992	4.0000	5	4.9985	4.9975	2.260	.10	4.50	3.9995	3.9987	4.0011	4.0005	
IR 6850	4	3.9992	4.0000	5	4.9985	4.9975	2.515	.10	5.01	3.9995	3.9987	4.0011	4.0005	-42
IR 6849 C	4 1/4	4.2492	4.2500	5	4.9985	4.9975	2.260	.10	3.47	4.2495	4.2487	4.2511	4.2505	
IR 6918	4 1/2	4.4992	4.5000	5 1/2	5.4985	5.4975	2.515	.10	5.57	4.4995	4.4987	4.5011	4.5005	-43
IR 6919	4 1/2	4.4992	4.5000	5 1/2	5.4985	5.4975	3.015	.10	6.68	4.4995	4.4987	4.5011	4.5005	-44
IR 6922	4 3/4	4.7483	4.7492	5 3/4	5.7483	5.7473	3.015	.12	7.02	4.7494	4.7487	4.7513	4.7506	-45
IR 6925	5	4.9990	5.0000	6	5.9983	5.9973	2.515	.12	6.13	4.9994	4.9985	5.0013	5.0006	-46
IR 6926	5	4.9990	5.0000	6	5.9983	5.9973	3.015	.12	7.35	4.9994	4.9985	5.0013	5.0006	-47
IR 6935	5 1/2	5.4990	5.5000	6 1/2	6.4983	6.4973	2.515	.12	6.68	5.4994	5.4985	5.5013	5.5006	-48
IR 6936	5 1/2	5.4990	5.5000	6 1/2	6.4983	6.4973	3.015	.12	8.01	5.4994	5.4985	5.5013	5.5006	-49
IR 2325	6	5.9990	6.0000	7 1/4	7.2481	7.2469	2.515	.12	9.22	5.9994	5.9985	6.0013	6.0006	
IR 2326	6	5.9990	6.0000	7 1/4	7.2481	7.2469	3.015	.12	11.06	5.9994	5.9985	6.0013	6.0006	-50
IR 2425	6 1/2	6.4990	6.5000	7 3/4	7.7481	7.7469	2.515	.12	9.92	6.4994	6.4985	6.5013	6.5006	
IR 2426	6 1/2	6.4990	6.5000	7 3/4	7.7481	7.7469	3.015	.12	11.90	6.4994	6.4985	6.5013	6.5006	
IR 2526	7	6.9990	7.0000	8 1/4	8.2481	8.2469	3.015	.12	12.73	6.9994	6.9985	7.0013	7.0006	
IR 2626	7 1/2	7.4988	7.5000	8 3/4	8.7480	8.7468	3.015	.16	13.57	7.4994	7.4983	7.5015	7.5007	
IR 2726	8	7.9988	8.0000	9 1/4	9.2480	9.2468	3.015	.16	14.40	7.9994	7.9983	8.0015	8.0007	

All dimensions in inches

These inner rings meet Military Standard MS 51962

1) Sorted by outside diameter.

# IN SEARCH of MAXIMUM CAPACITY

## The RBC TJ TandemRoller<sup>®</sup> Bearing

### What more capacity will do:

The rating life of roller bearings is given by  $L = \left(\frac{C}{P}\right)^{\frac{10}{3}}$  where **L** is the calculated fatigue life, **C**, the dynamic capacity, and **P**, the equivalent radial load. It is easy to see that increasing the capacity will increase the fatigue life under the same load conditions, however, the relationship between life and capacity is not linear.

To see how life changes with improved capacity and constant load, we calculate a fatigue life ratio  $\frac{L_2}{L_1}$  for 2 different capacity values **C**<sub>2</sub> and **C**<sub>1</sub> using the above equation:

$$\frac{L_2}{L_1} = \frac{\left(\frac{C_2}{P}\right)^{\frac{10}{3}}}{\left(\frac{C_1}{P}\right)^{\frac{10}{3}}} \quad \text{or} \quad \frac{L_2}{L_1} = \left(\frac{C_2}{C_1}\right)^{\frac{10}{3}}$$

From this relationship or from fig. 1 we can determine for example that a 10% improvement in capacity yields a 37% improvement in calculated fatigue life, while a 20% higher capacity gives 83% more life.

### Increasing the number of rollers

Next we explore the AFBMA formula for the dynamic capacity of radial roller bearings for ways to improve capacity:

$$C = f_c \cdot (i \cdot L_{\text{eff}} \cdot \cos(\alpha))^{\frac{7}{9}} \cdot Z^{\frac{3}{4}} \cdot D_w^{\frac{29}{27}}$$

For a given bearing width, changing the number of rows of rolling elements **i** is usually not an option and the effective roller length **L**<sub>eff</sub> can rarely be increased any further, for radial bearings **cos**(**α**) = **1** and the roller diameter **D**<sub>w</sub> can be increased only so much, before the outer ring wall thickness or the cage bar become too thin. This leaves only the factor **f**<sub>c</sub> and the number of rollers per row **z** for modification to boost capacity.

### Full complement of rollers

Although a full complement bearing design has the most rollers, factor **f**<sub>c</sub> is a maximum for a bearing with cage and modified line contact between rollers

and raceways. Full complement bearings are more sensitive to misalignment, have a greater coefficient of friction and therefore generate much more heat. Their speed limit is lower and they require re-lubrication more often because they have not only less space for lubricant storage, but use up the smaller amount of lubricant more rapidly than caged designs.

### The Tandem Roller Bearing (TJ-series) solutions.

The patented RBC solution to this dilemma has been to design and make a caged bearing with 2 rollers per cage pocket. The tandem rollers are still properly guided, while the cage retains sufficient strength. The improvement in capacity over a bearing with 1 roller per pocket typically ranges from 10% to 40%, giving 37% to 200% greater fatigue life.

This improved bearing performance has been used successfully in many critical applications, for example, helicopter blade bearings, gear and mud pump bearings, suspension bearings, and many others.

TJ bearing designs are shown in the following pages in this catalog. Contact RBC when applying a TJ bearing in your design.

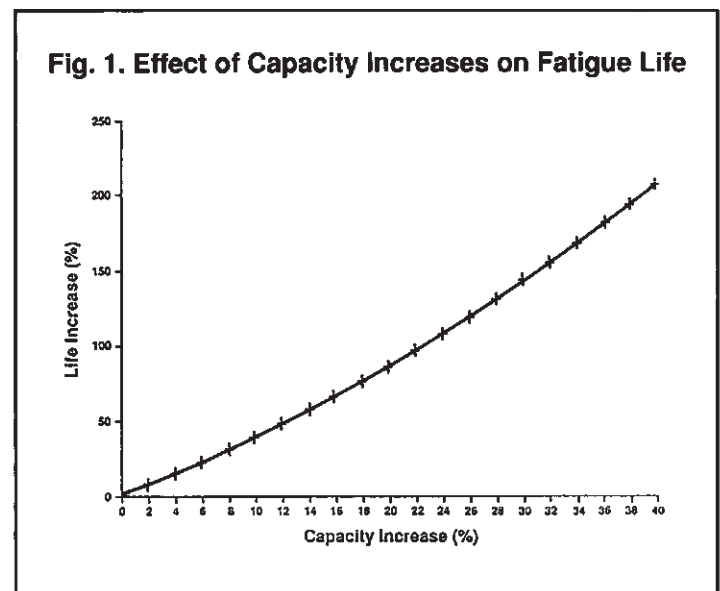

# Heavy Duty TJ TandemRoller® Bearings

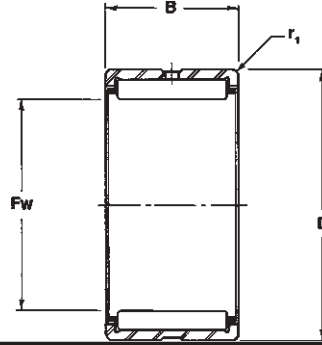

TJ TandemRoller® Bearing

BEARING PART NUMBER 1)	Fw Inside Diameter			D Outside Diameter		B Width +.000 -.005	r <sub>1</sub> Housing Fillet Max.	Housing Shoulder Dia. +/- 1/64"	Dynamic Capacity C (lbs.)	Static Capacity C <sub>0</sub> (lbs.)
	Nominal	Min.	Max.	Max.	Min.					
TJ 75317	7/8	.8759	.8768	1.5000	1.4995	1.063	.015	1 1/4	7,300	10,800
TJ 7194	1	1.0009	1.0018	1.5000	1.4995	1.000	.015	1 5/16	8,000	13,700
TJ 74765	1 1/16	1.0640	1.0649	1.6875	1.6870	1.000	.015	1 7/16	9,500	13,900
TJ 7214	1 1/8	1.1259	1.1268	1.6250	1.6245	1.000	.040	1 3/8	8,500	15,500
TJ 7215	1 1/8	1.1259	1.1268	1.6250	1.6245	1.250	.040	1 3/8	10,600	20,400
TJ 7235	1 1/4	1.2510	1.2519	1.7500	1.7495	1.250	.040	1 9/16	11,300	22,700
TJ 75117	1 3/8	1.3760	1.3769	2.0625	2.0619	1.000	.015	1 3/4	10,100	17,900
TJ 75129	1 1/2	1.5010	1.5019	2.2500	2.2494	1.000	.015	1 7/8	11,300	18,900
TJ 75318	1 1/2	1.5010	1.5019	2.3750	2.3744	1.250	.060	2	15,000	24,400
DTJ 75319	1 1/2	1.5010	1.5019	2.3750	2.3744	2.500	.060	2	25,800	48,900
TJ 7314	1 3/4	1.7510	1.7520	2.3125	2.3119	1.000	.060	2 1/16	11,500	23,900
TJ7315	1 3/4	1.7510	1.7520	2.3125	2.3119	1.250	.060	2 1/16	14,300	31,800
TJ7354	2	2.0011	2.0021	2.5625	2.5619	1.000	.060	2 5/16	12,500	27,700
TJ 7355	2	2.0011	2.0021	2.5625	2.5619	1.250	.060	2 5/16	15,600	36,800
TJ 8446	2 1/2	2.5011	2.5021	3.2500	3.2494	1.500	.080	2 7/8	19,000	46,600
TJ 8447	2 1/2	2.5011	2.5021	3.2500	3.2494	1.750	.080	2 7/8	22,200	56,900
TJ 8476	2 3/4	2.7511	2.7521	3.5000	3.4992	1.500	.080	3 1/8	19,500	49,800
TJ 8477	2 3/4	2.7511	2.7521	3.5000	3.4992	1.750	.080	3 1/8	22,800	60,900
TJ 8516	3	3.0011	3.0023	3.7500	3.7492	1.500	.080	3 3/8	20,900	56,000
TJ 8517	3	3.0011	3.0023	3.7500	3.7492	1.750	.080	3 3/8	24,400	68,500
DTJ 75168	3 1/4	3.2512	3.2524	4.2500	4.2492	4.000	.060	3 3/4	54,500	164,500
TJ 75310	3 5/16	3.3151	3.3160	4.0000	3.9992	1.500	.060	3 5/8	20,900	64,400
TJ 75309	3 5/16	3.3151	3.3160	4.0000	3.9992	1.650	.060	3 5/8	22,900	72,600
TJ 9608	3 1/2	3.5012	3.5014	4.5000	4.4992	2.000	.060	3 7/8	32,800	87,900
TJ 75177	3 13/16	3.8143	3.8157	4.3750	4.3742	1.500	.060	4	18,400	76,000
TJ 75311	4	4.0012	4.0024	4.8125	4.8118	2.125	.060	4 3/8	34,100	116,000
TJ 75176	4 1/16	4.0643	4.0657	4.6250	4.6242	1.500	.060	4 5/16	18,900	81,000
TJ 75312	4 1/2	4.5012	4.5026	5.3125	5.3118	2.080	.060	4 7/8	36,200	127,000
TJ 6769	4 1/2	4.5012	4.5026	6.0000	5.9990	2.250	.100	5 1/4	49,600	119,000
TJ 6770	4 1/2	4.5012	4.5026	6.0000	5.9990	2.500	.100	5 1/4	55,400	137,000
DTJ 75169	4 1/2	4.5012	4.5026	6.0000	5.9990	4.500	.100	5 1/4	85,800	236,000
TJ 74986	5	5.0013	5.0027	6.0000	5.9990	2.000	.100	5 1/2	39,000	135,000
TJ 6849	5	5.0013	5.0027	6.5000	6.4990	2.250	.100	5 3/4	54,000	137,000
TJ 6918	5 1/2	5.5013	5.5027	7.0000	6.9990	2.500	.100	6 1/4	62,000	169,000
TJ 6919	5 1/2	5.5013	5.5027	7.0000	6.9990	3.000	.100	6 1/4	74,200	213,000
DTJ 75170	5 1/2	5.5013	5.5027	7.0000	6.9990	6.000	.100	6 1/4	127,000	425,000
TJ 6926	6	6.0013	6.5029	7.5000	7.4988	3.000	.120	6 5/8	79,300	239,000
TJ 6935	6 1/2	6.5013	6.5029	8.0000	7.9988	2.500	.120	7 1/8	67,500	200,000
DTJ 75166	8	8.0014	8.0032	10.1250	10.1236	7.750	.160	9 1/4	260,000	830,000

All dimensions in inches.  
Inquire for sizes not listed.

See pages 10-12 for available inner rings.  
Inner rings must be ordered separately.

1) Prefix DTJ denotes a double row bearing.



# Heavy Duty TJ TandemRoller® Bearings

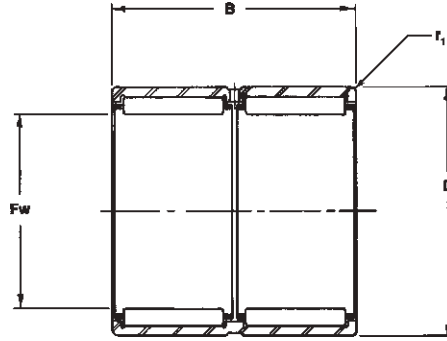

DTJ Double Row TandemRoller® Bearing

	Limit Speed (rpm)	Recommended Shaft Diameter				Recommended Housing Bore						BEARING PART NUMBER 1)
		ISO h6, use with H7 hsg fit		ISO f6, use with N7 hsg fit		Slip Fit ISO H7			Press Fit ISO N7			
		Max.	Min.	Max.	Min.	Min.	Max.	Mean Fit	Min.	Max.	Mean Fit	
	13,000	.8750	.8745	.8742	.8737	1.5000	1.5010	.0007L	1.4987	1.4997	.0006T	TJ 75317
	11,800	1.0000	.9995	.9992	.9987	1.5000	1.5010	.0007L	1.4987	1.4997	.0006T	TJ 7194
	11,000	1.0625	1.0620	1.0617	1.0612	1.6875	1.6885	.0007L	1.6862	1.6872	.0006T	TJ 74765
	10,500	1.1250	1.1245	1.1242	1.1237	1.6250	1.6260	.0007L	1.6237	1.6247	.0006T	TJ 7214
	10,500	1.1250	1.1245	1.1242	1.1237	1.6250	1.6260	.0007L	1.6237	1.6247	.0006T	TJ 7215
	9,400	1.2500	1.2494	1.2490	1.2484	1.7500	1.7510	.0007L	1.7487	1.7497	.0006T	TJ 7235
	8,500	1.3750	1.3744	1.3740	1.3734	2.0625	2.0637	.0009L	2.0610	2.0621	.0006T	TJ 75117
	7,800	1.5000	1.4994	1.4990	1.4984	2.2500	2.2512	.0009L	2.2485	2.2496	.0006T	TJ 75129
	7,800	1.5000	1.4994	1.4990	1.4984	2.3750	2.3762	.0009L	2.3735	2.3746	.0006T	TJ 75318
	7,100	1.5000	1.4994	1.4990	1.4984	2.3750	2.3762	.0009L	2.3735	2.3746	.0006T	DTJ 75319
	6,700	1.7500	1.7494	1.7490	1.7484	2.3125	2.3137	.0009L	2.3110	2.3121	.0006T	TJ 7314
	6,700	1.7500	1.7494	1.7490	1.7484	2.3125	2.3137	.0009L	2.3110	2.3121	.0006T	TJ 7315
	5,900	2.0000	1.9993	1.9988	1.9981	2.5625	2.5637	.0009L	2.5610	2.5621	.0006T	TJ 7354
	5,900	2.0000	1.9993	1.9988	1.9981	2.5625	2.5637	.0009L	2.5610	2.5621	.0006T	TJ 7355
	4,700	2.5000	2.4993	2.4988	2.4981	3.2500	3.2514	.0011L	3.2482	3.2496	.0006T	TJ 8446
	4,700	2.5000	2.4993	2.4988	2.4981	3.2500	3.2514	.0011L	3.2482	3.2496	.0006T	TJ 8447
	4,300	2.7500	2.7493	2.7488	2.7481	3.5000	3.5014	.0011L	3.4982	3.4996	.0007T	TJ 8476
	4,300	2.7500	2.7493	2.7488	2.7481	3.5000	3.5014	.0011L	3.4982	3.4996	.0007T	TJ 8477
	3,900	3.0000	2.9993	2.9988	2.9981	3.7500	3.7514	.0011L	3.7482	3.7496	.0007T	TJ 8516
	3,900	3.0000	2.9993	2.9988	2.9981	3.7500	3.7514	.0011L	3.7482	3.7496	.0007T	TJ 8517
	3,300	3.2500	3.2491	3.2486	3.2477	4.2500	4.2514	.0011L	4.2482	4.2496	.0007T	DTJ 75168
	3,500	3.3125	3.3116	3.3111	3.3102	4.0000	4.0014	.0011L	3.9982	3.9996	.0007T	TJ 75310
	3,500	3.3125	3.3116	3.3111	3.3102	4.0000	4.0014	.0011L	3.9982	3.9996	.0007T	TJ 75309
	3,300	3.5000	3.4991	3.4986	3.4977	4.5000	4.5014	.0011L	4.4982	4.4996	.0007T	TJ 9608
	3,100	3.8125	3.8116	3.8111	3.8102	4.3750	4.3764	.0011L	4.3732	4.3746	.0007T	TJ 75177
	3,000	4.0000	3.9991	3.9986	3.9977	4.8125	4.8141	.0011L	4.8105	4.8120	.0008T	TJ 75311
	2,900	4.0625	4.0616	4.0611	4.0602	4.6250	4.6266	.0012L	4.6230	4.6245	.0008T	TJ 75176
	2,600	4.5000	4.4991	4.4986	4.4977	5.3125	5.3141	.0011L	5.3105	5.3120	.0008T	TJ 75312
	2,600	4.5000	4.4991	4.4986	4.4977	6.0000	6.0016	.0013L	5.9980	5.9995	.0008T	TJ 6769
	2,600	4.5000	4.4991	4.4986	4.4977	6.0000	6.0016	.0013L	5.9980	5.9995	.0008T	TJ 6770
	2,300	4.5000	4.4991	4.4986	4.4977	6.0000	6.0016	.0013L	5.9980	5.9995	.0008T	DTJ 75169
	2,400	5.0000	4.9990	4.9983	4.9973	6.0000	6.0016	.0013L	5.9980	5.9995	.0008T	TJ 74986
	2,400	5.0000	4.9990	4.9983	4.9973	6.5000	6.5016	.0013L	6.4980	6.4995	.0008T	TJ 6849
	2,100	5.5000	5.4990	5.4983	5.4973	7.0000	7.0016	.0013L	6.9980	6.9995	.0008T	TJ 6918
	2,100	5.5000	5.4990	5.4983	5.4973	7.0000	7.0016	.0013L	6.9980	6.9995	.0008T	TJ 6919
	1,900	5.5000	5.4990	5.4983	5.4973	7.0000	7.0016	.0013L	6.9980	6.9995	.0008T	DTJ 75170
	2,000	6.0000	5.9990	5.9983	5.9973	7.5000	7.5018	.0015L	7.4976	7.4994	.0009T	TJ 6926
	1,800	6.5000	6.4990	6.4983	6.4973	8.0000	8.0018	.0015L	7.9976	7.9994	.0009T	TJ 6935
	1,350	8.0000	7.9989	7.9980	7.9969	10.1250	10.1270	.0017L	10.1224	10.1244	.0009T	DTJ 75166

1) Location and number of lubricating holes may differ

# TECHNICAL DATA

## 1. Introduction

The methods, equations, and technical data presented in this section should be sufficient to select the correct bearings and estimate their performance for a wide range of applications. For applications with severe or unusual operating conditions, RBC is prepared to provide an in-depth analysis and recommend the most suitable bearing arrangement. Where standard bearings cannot be used, RBC can meet the application requirements with a special bearing design, specifically tailored for optimum performance.

## 2. Capacity and Fatigue Life of Roller Bearings

DYNAMIC CAPACITY  $C$  [lbf,N], or “basic load rating” for a roller bearing is that calculated, constant, radial load, which a group of apparently identical bearings with a stationary outer ring can theoretically endure for a fatigue life of  $10^6$  revolutions of the inner ring.

STATIC CAPACITY  $C_O$  [lbf,N], or “static load rating” is that uniformly distributed static radial load, which produces a maximum theoretical contact stress of 4000 MPa (580,000 psi).

FATIGUE LIFE,  $L_{10}$  [rev, hrs], is a statistical measure of the life which 90% of a large group of apparently identical bearings will complete or exceed. For a single bearing,  $L_{10}$  also refers to the life associated with 90% reliability.

Median Life,  $L_{50}$  is usually not more than five times  $L_{10}$ .

The relationship between rating life, capacity and load is:

$$L_{10 \text{ rev}} = \left( \frac{C}{P_e} \right)^{\frac{10}{3}} \quad \text{with } \begin{array}{l} L_{10} = \text{rating life [}10^6 \text{ rev]} \\ C = \text{dynamic capacity [lbf, N]} \\ P_e = \text{equivalent load [lbf, N]} \end{array} \quad (1)$$

*(See Section 3.1)*

To obtain the rating life in [hrs], use

$$L_{10 \text{ hrs}} = \frac{16667}{n_e} * \left( \frac{C}{P_e} \right)^{\frac{10}{3}} \quad \text{with } n_e = \text{equivalent speed [rpm]} \quad (2)$$

*(See Section 3.1)*

The equations are valid in the range of approximately 100 hrs to 100,000 hrs of life. At the low end, extreme loads or speeds may adversely affect life, at the high end, metal fatigue may never be a factor in bearing service life.

### 2.1 Required Bearing Load Capacity

Solving eq.(2) for the dynamic capacity  $C$ , we find:

$$C_{\text{req}} = P_e * \left( \frac{L_{10} * n_e}{16667} \right)^{0.3} \quad (3)$$

Use for applications, where a bearing must last a certain number of hours under given load and speed conditions.

Normally, bearings with rigidly mounted outer rings can support static loads up to the static capacity without detriment. The static load limit may also be used to evaluate momentary shock loads in dynamic applications and the maximum load at very slow rotation or oscillation, e.g.:

$$n_{\text{slow}} = < \frac{4}{d} \quad \text{d is the bearing inside diameter [in]} \quad (4)$$

## 2.2 Adjustments to Bearing Capacity

### 2.2.1 Raceway Hardness

The capacities given in the dimensional table are valid only if all load carrying bearing components are properly heat treated to a minimum hardness of HRc 58. The equivalent strength of material is approximately 300,000 psi. In applications without an inner ring, the shaft becomes an integral bearing component.

If one or more bearing components possess a hardness of less than HRc 58, both dynamic and static capacities must be reduced by factors given in table 1. A hardness of less than HRc 40 is not recommended.

The adjusted bearing capacities  $C'$  and  $C'_O$  become

$$\text{Adjusted dynamic capacity: } C' = f_{HD} * C \quad (5)$$

$$\text{Adjusted static capacity: } C'_O = f_{HS} * C_O \quad (6)$$

### 2.2.2 Operating Temperature

RBC roller bearings without seals and metallic cages are heat stabilized and may be used at operating temperatures between -40° F (-40°C) and +300° F (150° C) with no loss of capacity. Where applicable, temperature limits of seals, cage, and lubricant must be considered.

Successful operation at higher temperatures requires a different heat treatment, which reduces hardness proportionally. Alternatively, more temperature resistant bearing materials can be substituted. Consult with RBC Engineering for recommendations and hot hardness factors.

Hardness HRc	Hardness HV	Dynamic $f_{HD}$	Static $f_{HS}$
58	655	1.00	1.00
56	617	.88	.99
54	580	.77	.97
52	545	.67	.94
50	513	.59	.90
48	485	.51	.85
46	458	.43	.76
44	435	.37	.68
42	413	.31	.60
40	393	.26	.55

Table 1. Capacity reduction factors

## 2.3 Thrust Capacity of Radial Cylindrical Roller Bearings

Depending on internal design and operating conditions, cylindrical roller bearings can support considerable thrust loads, which makes them suitable for use as locating bearings. The main design criterion is the length to diameter ratio of the roller itself. Bearings equipped with roller lengths more than 2.5 times the diameter are called needle roller bearings and should not be used to support thrust loads.

The maximum permissible thrust load is given as a percent of the actual radial load applied and depends on speed and lubrication conditions. It is generally safe to allow a dynamic thrust load equal to 10% of the radial load.

## 2.4 Adjustments to Fatigue Life

If bearing design and operation deviate significantly from normal, it may be necessary to use additional factors to estimate the fatigue life  $L_{na}$

$$L_{na} = a_1 * a_2 * a_3 * L_{10} \quad (7)$$

where  $L_{na}$  = adjusted rating life [hrs, rev]

$a_1$  = reliability factor (see table 2)

$a_2$  = material factor

$a_3$  = user operating factor

Reliability %	$L_n$	Reliability Factor $a_1$
90	$L_{10}$	1
95	$L_5$	0.62
96	$L_4$	0.53
97	$L_3$	0.44
98	$L_2$	0.33
99	$L_1$	0.21

Table 2. Reliability Factors,  $a_1$

The materials and bearing technology factor  $a_2 = 1$  for standard bearings. Adjustment factor  $a_3$  takes into account unusual or extreme operating conditions such as shock loads, misalignment, and lubrication. RBC rollers are crowned to reduce the danger of roller end loading and to allow for misalignment of up to 4' (0.0012 in/in). Greater misalignment or moment loading result in stress concentrations, which may reduce the rating life significantly. Consult with RBC for a detailed analysis.

## 3. Equivalent bearing speed and load

### 3.1 Mean effective bearing speed

A mean effective bearing speed  $n_e$  [rpm] must be calculated for bearings subject to variable loads and speeds within a duty cycle. It is the weighted average of all individual speed components.

$$n_e = \sum \left( \frac{n_i * t_i}{100} \right) \quad (8)$$

$$= \frac{n_1 * t_1}{100} + \frac{n_2 * t_2}{100} + \dots \quad \text{where } n_i = \text{individual speed [rpm]} \\ t_i = \text{time interval in [\%] of total time}$$

### 3.2 Equivalent bearing load

The general equation to compute the equivalent bearing load  $P_e$  is:

$$P_e = \sqrt[q]{\sum \left( \frac{F_i^q * n_i * t_i}{n_e * 100} \right)} \quad (9)$$

$$= \sqrt[q]{\frac{F_1^q * n_1 * t_1}{n_e * 100} + \frac{F_2^q * n_2 * t_2}{n_e * 100} + \dots}$$

In the special case of constant speed this equation reduces to:

$$P_e = \sqrt[q]{\sum \left( \frac{F_i^q * t_i}{100} \right)} \quad (10)$$

$$= \sqrt[q]{\frac{F_1^q * t_1}{100} + \frac{F_2^q * t_2}{100} + \dots} \quad \text{where } q = 10/3 \text{ for roller bearings} \\ F_i = \text{individual radial load [lbf, N]}$$

If the bearing is subject to repeated shock or impact loads, the equivalent load  $P_e$  or its individual components should be multiplied by a suitable shock load factor. The product of load and shock load factor should not exceed the bearing static capacity to prevent brinelling of raceways and rollers.

Loading	Shock Load Factor
Uniform and constant	1.00
Variable and light shock	1.50
Vibration and moderate shock	2.00
Heavy and severe shock	3.00

Table 3. Load Modification Factors

## 4. Limiting Speed

The limiting speed values in the dimensional tables apply to bearings lubricated with oil of proper viscosity, operating under low to medium load. Poor cooling conditions, bearing misalignment, and improper diametral bearing clearance will cause the bearing to heat up and reduce the maximum permissible speed. Grease lubricated bearings should not exceed 65% of the values given in the tables. The maximum speed of bearings with contacting lip seals is generally limited to a lip surface speed of 1000 ft/min.

## 5. Shaft & Housing Fits

The dimensional tables list loose and interference fits for inner and outer rings. The correct fit depends on type and severity of the load. To prevent rotation and wear, the ring subject to rotating loads must be press fitted. This will be the inner ring in most applications. The ring subject to a stationary load may be loosely fitted.

The housing interference fit ISO N7 given in the tables covers most applications with normal loads to 25% of dynamic capacity and light to moderate shock loads. Higher loads, or heavy shock loads, or thin-walled housings may require a tighter interference fit, e.g. ISO P7.

Likewise, loads above 25% of dynamic capacity, or heavy shock loads, or a hollow shaft may require a shaft interference fit per ISO n6. To determine tolerances per P7 or n6, proceed as follows: The nominal housing bore is the maximum bearing outside diameter, the nominal shaft diameter is the maximum inner ring inside diameter. Find the nominal housing bore diameter or shaft diameter respectively in table 4 and add the tolerances to the nominal dimension.

Nominal Bearing OD Range[in]	Upper & Lower Tolerance ISO P7		Nominal Inner Ring ID Range[in]	Upper & Lower Tolerance ISO n6	
3/4 - 1 1/8	-0.0006	-0.0014	1/2 - 11/16	+0.0009	+0.0005
1 3/16 - 1 15/16	-0.0007	-0.0017	3/4 - 1 1/8	+0.0011	+0.0006
2 - 3	-0.0008	-0.0020	1 3/16 - 1 15/16	+0.0013	+0.0007
3 1/4 - 4 1/2	-0.0009	-0.0023	2 - 3	+0.0015	+0.0008
4 3/4 - 7	-0.0011	-0.0027	3 1/4 - 4 1/2	+0.0018	+0.0009
7 1/8 - 9 3/4	-0.0013	-0.0031	4 3/4 - 7	+0.0020	+0.0011
10 - 12 3/8	-0.0014	-0.0035	7 1/8 - 9 3/4	+0.0024	+0.0012
12 1/2 - 15 5/8	-0.0016	-0.0039	10 - 12 3/8	+0.0026	+0.0013

Table 4. Housing tolerance P7 and shaft tolerance n6

Due to lower stiffness, bearing inner and outer rings usually conform to the shape of shaft and housing bore respectively, with little attenuation of taper and out-of-roundness. The quality of user supplied mounting surfaces must therefore be sufficient for the intended application.

The bearing operating clearance should be checked in cases where both inner and outer rings are press fitted or where a large temperature gradient exists between shaft and housing.

The user supplied shaft is an integral part of bearings without an inner ring and must meet at least the minimum requirements for rolling element bearings: Surface hardness of HRC 58 min, surface finish 16 rms, through hardened or surface hardened 0.030 to 0.050" deep (this figure depends on bearing dimensions and load) with sufficient core hardness, roundness and taper tolerance less than 50 % of the diameter tolerance.

## 6. Lubrication

Lubricants serve very important purposes in rolling element bearings, they

- protect bearing surfaces from rust and corrosion.
- reduce rolling and sliding friction.
- prevent metal-to-metal contact between rollers and raceways.
- carry heat out of the bearing contact area.
- form a barrier (grease) against external contaminants.
- remove wear particles from the bearing.

Lack of lubrication or inadequate lubrication is probably the single most common cause of bearing failure.

### 6.1 Grease Lubrication

The following check list may be helpful in grease selection:

- Suitability for the expected operating temperature and speed. Select a lower NLGI grade for low temperature operation.
- Compatibility with other greases, oils, and rust preventatives. To be compatible, products usually must have the same type oil and thickener.
- Load carrying ability. Some high temperature greases may significantly reduce bearing load capacity.
- Resistance to water and other contaminants. Balance water repellent properties against water emulsifying and water soluble properties. Note, a water repellent grease may not be able to protect the bearing surfaces against condensation and water, which has breached the grease barrier.
- Required additives for extreme pressure (EP), aging and oxidation resistance.

Historically, greases based on different thickeners had distinctly different properties with respect to operating temperature and behavior towards water. However, modern compounding technology has improved on many of the initial limitations and blurred the distinctions. The most widely used general purpose bearing grease today is a Lithium based, mineral oil type, water emulsifying grease, NLGI grade 2, with EP and other additives.

It takes relatively little lubricant to maintain an adequate lubricating film. In many applications, relubrication every 10 - 20,000 hrs would be sufficient for that purpose alone.

In those cases where the lubricants primary function is to protect the bearing from contamination, the relubrication period must be adjusted to maintain a protective barrier at all times. There are no fixed rules as to how often relubrication should take place, it is strictly a function of the environmental conditions. The harsher the operating conditions, the shorter the relubrication period. A visual examination of the bearings may indicate the need for more grease when much of the grease collar in the seal area has been lost.

The maximum recommended quantity of grease in a roller bearing is a function of operating speed. Pumping a high speed bearing full of grease will cause overheating, possibly grease loss after melting, and eventual bearing failure due to lack of lubricant. Table 5 provides a guideline for grease fill as a percent of free interior bearing space versus the operating speed  $n$  as a percent of limiting speed  $n_L$ . Visual examination of the bearing for compliance is sufficient.

Operating speed $n$	Percent of speed limit $n_L$	Grease fill % of free space
slow	$n \leq 10\% n_L$	100%
medium	$10\% < n < 20\% n_L$	50%
high	$n \geq 20\% n_L$	10%
very high	$n \geq 65\% n_L$	(oil lube required)

Table 5. Recommended grease volume.

## 6.2 Oil lubrication

The more demanding bearing applications involving high operating speed, high temperatures, heat generation, need for minimum friction, etc., usually require oil lubrication.

As with grease, the primary concern when selecting an oil is its suitability for the expected operating temperature. If the viscosity at operating temperature is too low, a hydrodynamic lubricating film between rollers and raceways will be too thin to prevent metal to metal contact and the adjusted bearing life will be less than the theoretical  $L_{10}$  life. Likewise, good separation of the bearing components by a thick lubricant film can more than double the  $L_{10}$  life.

The minimum oil viscosity at operating temperature should not fall below 12 cSt. The following equation can be used for a first estimate of the film parameter  $\Lambda$  for needle roller bearings type SJ:

$$\Lambda = 1.6 \cdot 10^{-4} \cdot (\nu \cdot n)^{0.71} \cdot F^{1.11} \quad (11)$$

with  $\nu$  = viscosity @ operating temperature [cSt]  
 $n$  = bearing speed [rpm]  
 $F$  = inner raceway diameter [in]

A film parameter  $\Lambda > 1$  enhances fatigue life,  $\Lambda < 1$  shortens fatigue life.

In oil sump lubrication systems, the oil level at rest should not cover more than half the diameter of the lowest roller. Bearings subject to heavy loads and speeds may develop so much heat that a recirculating oil system must be used to remove excess heat. Bearings operating near the speed limit or beyond should be lubricated with oil mist.

# TYPICAL APPLICATIONS

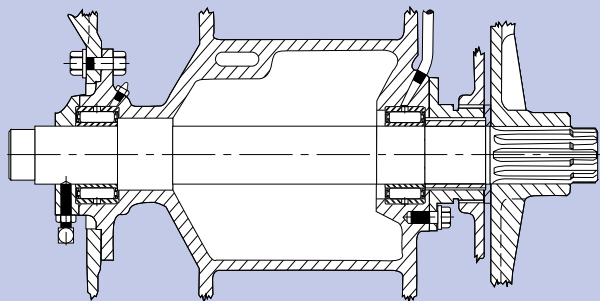

**Hoist Drum Shaft** — The long slender shaft of such an application is another point with inherent misalignment and deflection. Pitchlign® bearings are indicated to maintain its free-rolling, high capacity operations under adverse conditions.

**Pumping Units** — Center iron and equalizer applications, with oscillating service is best served by Pitchlign® bearings. With the properly controlled and spaced rollers, creepage of the rollers and cage occur to minimize fretting corrosion and friction oxidation.

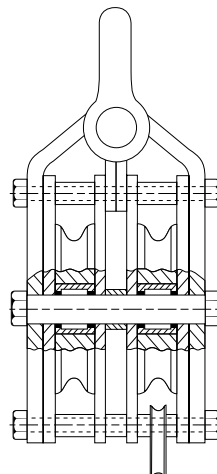
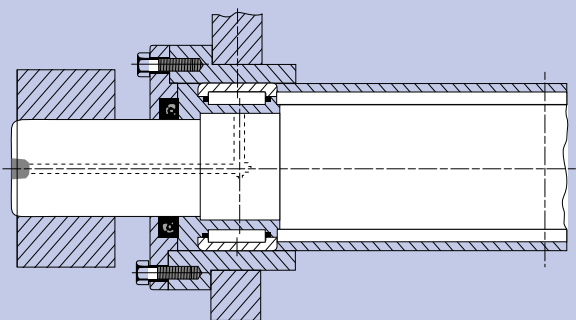

**Sheave Blocks** — Crown blocks and traveling blocks of portable drilling equipment use Pitchlign® bearings for ease of assembly, ease of lubrication and compactness combined with minimum friction and dependable service.

**Steel Mill Equipment** — Pipe handling tables use Pitchlign® bearings for maximum capacity, minimum friction, compactness, ease of lubrication and maintenance-free service.

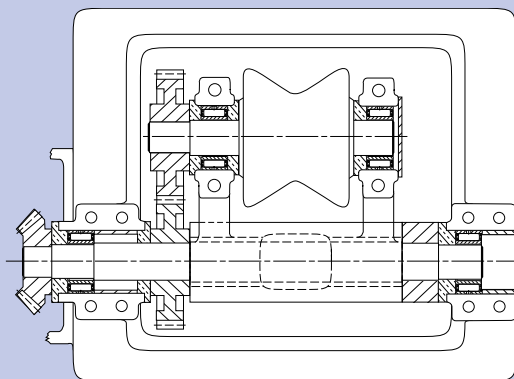



**Gear Pumps** — Higher pressures and speeds of today's efficient gear pumps, more than ever demand an individually controlled roller design of a bearing such as Pitchlign®. The deflection due to the high internal hydraulic loading, together with the inherent problem of alignment cannot be taken care of by any other type bearing.

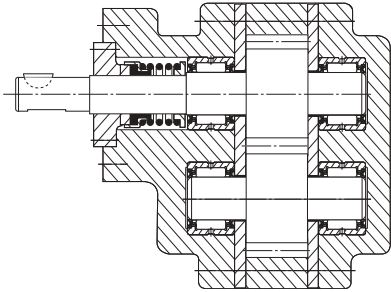

**Paper Converting Machines** — To maintain today's fabulous output of paper converting machinery, Pitchlign® bearings are used on the eccentrics and main bearings of paper punch presses where they withstand speed, heavy impact and shaft deflection.

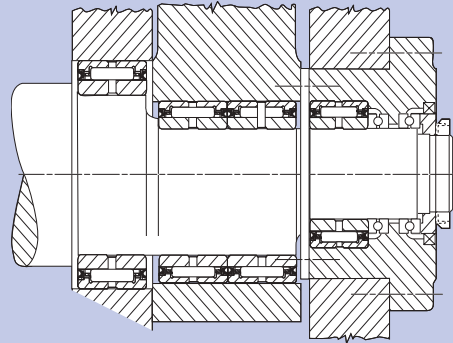

**Machine Tools** — One such application is the planet gears and mainshaft bearings of a clutch drive of a mechanical press. Pitchlign® bearings are ideally suited for planet gear applications where centrifugal force and torsional deflection of the planet cage is present. Pitchlign® bearing cages are supported by the integral outer ring flanges, maintaining proper guidance of individual rollers, regardless of the centrifugal force.

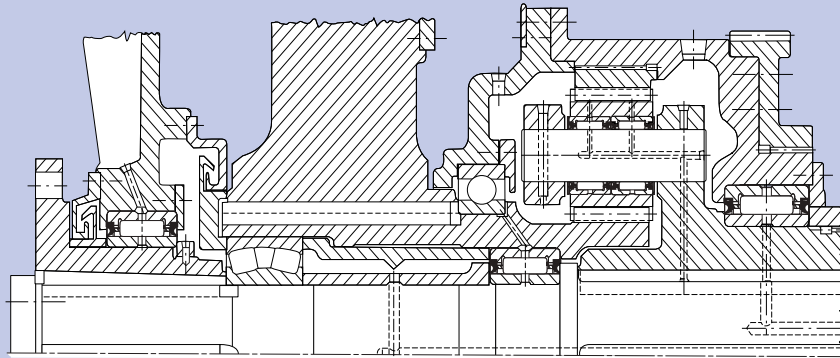

**Textile Machinery** — Calender rolls, where space is a problem, is another place where the Pitchlign® bearing with its maximum capacity, minimum size and thrust free operation fulfills all requirements. The sealed Pitchlign® bearing also assures stain-free batts.

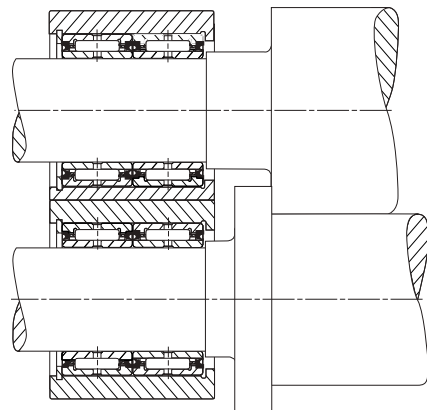

**Power Transmission** — In gear boxes and transmissions of all types, the Pitchlign® bearing is used due to its maximum capacity, minimum size and thrust free service. The sealing feature of the sealed Pitchlign® bearing simplifies design, assembly and inventory of parts.

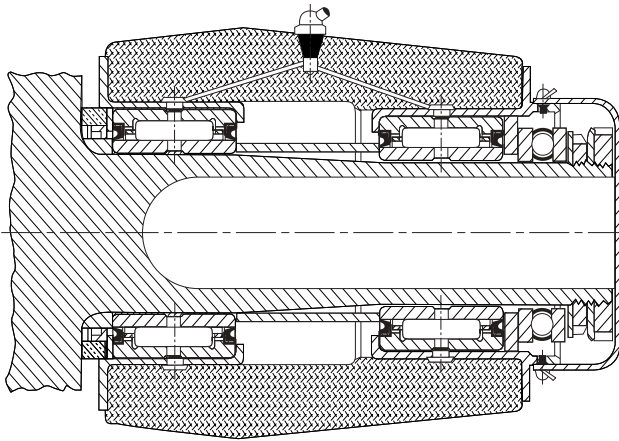
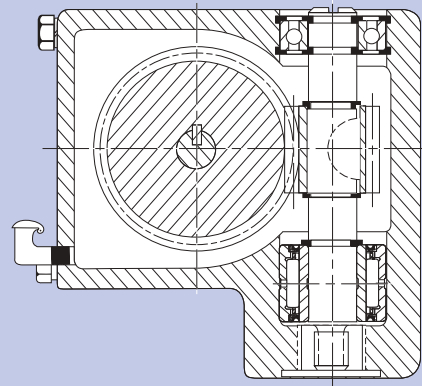

**Pitchlign® Aircraft Bearing** applied to the horizontal hinge of an early model helicopter rotor. The shaft, being cantilevered, introduces a severe deflection problem. The Pitchlign® bearing, with its individually controlled rollers prevents skewing and locking even with the severe end loading present.

**Pitchlign® Aircraft Bearing** mounted in a universal joint type design of intersecting horizontal and vertical hinges of a helicopter. The minimum dimensions and maximum capacity plus the creepage of the rollers and cage under oscillating service makes the Pitchlign® bearing an ideal bearing for such applications.

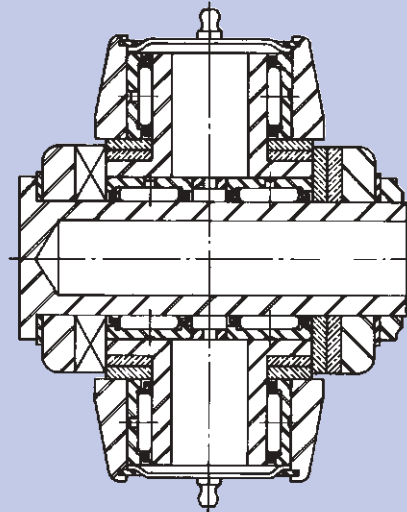

# Pitchlign® Roller Bearing Interchange Tables

Torrington	RBC	Size
HJ-101812	SJ7133	5/8
HJ-122012	SJ7153	3/4
HJ-122016	SJ7154	3/4
HJ-142212	SJ7173	7/8
HJ-142216	SJ7174	7/8
HJ-162412	SJ7193	1
HJ-162416	SJ7194	1
HJ-182616	SJ7214	1 1/8
HJ-182620	SJ7215	1 1/8
HJ-202816	SJ7234	1 1/4
HJ-202820	SJ7235	1 1/4
HJ-223016	SJ7254	1 3/8
HJ-223020	SJ7255	1 3/8
HJ-243316	SJ7274	1 1/2
HJ-243320	SJ7275	1 1/2
HJ-263516	SJ7294	1 5/8
HJ-263520	SJ7295	1 5/8
HJ-283716	SJ7314	1 3/4
HJ-283720	SJ7315	1 3/4
HJ-303920	SJ7335	1 7/8
HJ-324116	SJ7354	2
HJ-324120	SJ7355	2
HJ-364824	SJ8406	2 1/4
HJ-364828	SJ8407	2 1/4
HJ-405224	SJ8446	2 1/2
HJ-405228	SJ8447	2 1/2
HJ-445616	SJ8474	2 3/4
HJ-445624	SJ8475	2 3/4
HJ-445628	SJ8477	2 3/4
HJ-486024	SJ8516	3
HJ-486028	SJ8517	3
HJ-526828	SJ9567	3 1/4
HJ-526832	SJ9568	3 1/4
HJ-567232	SJ9608	3 1/2
HJ-607632	SJ9648	3 3/4
HJ-648032	SJ9688	4
HJ-688432	SJ9728	4 1/4
HJ-729636	TJ6769	4 1/2
HJ-729640	TJ6770	4 1/2
HJ-8010436	SJ6849	5
HJ-8010440	SJ6850	5
HJ-8011240	TJ6918	5 1/2
HJ-8011248	TJ6919	5 1/2
HJ-8012040	SJ6925	6
HJ-9612048	SJ6926	6
HJ-10412840	SJ6935	6 1/2
HJ-10412848	SJ6936	6 1/2
HJ-11614648	SJ2326	7 1/4
HJ-12415448	SJ2426	7 3/4
HJ-13216248	SJ2526	8 1/4
HJT-101816	SJ7134S	5/8
HJT-122016	SJ7154S	3/4
HJT-142216	SJ7174S	7/8
HJT-162416	SJ7194S	1
HJT-182620	SJ7215S	1 1/8
HJT-202820	SJ7235S	1 1/4
HJT-223020	SJ7255S	1 3/8
HJT-243320	SJ7275S	1 1/2
HJT-263520	SJ7295S	1 5/8
HJT-283720	SJ7315S	1 3/4
HJT-324120	SJ7355S	2
HJT-364828	SJ8407S	2 1/4
HJT-405228	SJ8447S	2 1/2
HJT-445628	SJ8477S	2 3/4
HJT-486028	SJ8517S	3
HJTT-101816	SJ7134SS	5/8
HJTT-122816	SJ7154SS	3/4
HJTT-142216	SJ7174SS	7/8
HJTT-162416	SJ7194SS	1
HJTT-182620	SJ7215SS	1 1/8
HJTT-202820	SJ7235SS	1 1/4
HJTT-223020	SJ7255SS	1 3/8
HJTT-243320	SJ7275SS	1 1/2
HJTT-263520	SJ7295SS	1 5/8
HJTT-283720	SJ7315SS	1 3/4
HJTT-324120	SJ7355SS	2

Torrington	RBC	Size
HJTT-364828	SJ8407SS	2 1/4
HJTT-405228	SJ8447SS	2 1/2
HJTT-445628	SJ8477SS	2 3/4
HJTT-486028	SJ8517SS	3
IR-061012	IR7133	5/8
IR-081212	IR7153	3/4
IR-081216	IR7154	3/4
IR-101412	IR7173	7/8
IR-111412	IR7173C	7/8
IR-101416	IR7174	7/8
IR-121612	IR7193	1
IR-121616	IR7194	1
IR-131616	IR7194C	1
IR-141816	IR7214	1 1/8
IR-141820	IR7215	1 1/8
IR-151816	IR7214C	1 1/8
IR-151820	IR7215C	1 1/8
IR-162016	IR7234	1 1/4
IR-162020	IR7235	1 1/4
IR-182216	IR7254	1 3/8
IR-182220	IR7255	1 3/8
IR-192420	IR7275	1 1/2
IR-202416	IR7274C	1 1/2
IR-202420	IR7275C	1 1/2
IR-212616	IR7294	1 5/8
IR-212620	IR7295	1 5/8
IR-222620	IR7295C	1 5/8
IR-222820	IR7315D	1 3/4
IR-232816	IR7314	1 3/4
IR-232820	IR7315	1 3/4
IR-242816	IR7314C	1 3/4
IR-242820	IR7315C	1 3/4
IR-253020	IR7335	1 7/8
IR-243220	IR7355D2	2
IR-253220	IR7355D1	2
IR-263220	IR7355D	2
IR-273216	IR7354	2
IR-273220	IR7355	2
IR-283624	IR8406	2 1/4
IR-283628	IR8407	2 1/4
IR-314024	IR8446	2 1/2
IR-314028	IR8447	2 1/2
IR-324024	IR8446C	2 1/2
IR-324028	IR8447C	2 1/2
IR-354428	IR8477	2 3/4
IR-364424	IR8476C	2 3/4
IR-364428	IR8477C	2 3/4
IR-384828	IR8517	3
IR-404824	IR8516C	3
IR-404828	IR8517C	3
IR-445228	IR9567	3 1/4
IR-445232	IR9568	3 1/4
IR-475632	IR9608	3 1/2
IR-485632	IR9608C	3 1/2
IR-506032	IR9648	3 3/4
IR-526032	IR9648C	3 3/4
IR-526432	IR9688D	4
IR-546432	IR9688	4
IR-566432	IR9688C	4
IR-566832	IR9728	4 1/4
IR-606832	IR9728C1	4 1/4
IR-607236	IR6769	4 1/2
IR-648036	IR6849	5
IR-648040	IR6850	5
IR-688036	IR6849C	5
IR-728840	IR6918	5 1/2
IR-728848	IR6919	5 1/2
IR-809640	IR6925	6
IR-809648	IR6926	6
IR-8810440	IR6935	6 1/2
IR-8810448	IR6936	6 1/2
IR-9611648	IR2326	7 1/4
IR-10412448	IR2426	7 3/4
IR-11213248	IR2526	8 1/4
IR-12014048	IR2626	8 3/4
IR-12814848	IR2726	9 1/4



**SJ**



**IR**



**TJ**

# Pitchlign® Roller Bearing Interchange Tables

McGill	RBC	Size
MR-10	SJ7134	5/8
MR-10-N	SJ7133	5/8
MR-10-RS	SJ7134S	5/8
MR-10-RSS	SJ7134SS	5/8
MR-12	SJ7154	3/4
MR-12-N	SJ7153	3/4
MR-12-RS	SJ7154S	3/4
MR-12-RSS	SJ7154SS	3/4
MR-14	SJ7174	7/8
MR-14-N	SJ7173	7/8
MR-14-RS	SJ7174S	7/8
MR-14-RSS	SJ7174SS	7/8
MR-16	SJ7194	1
MR-16-N	SJ7193	1
MR-16-RS	SJ7194S	1
MR-16-RSS	SJ7194SS	1
MR-18	SJ7215	1 1/8
MR-18-N	SJ7214	1 1/8
MR-18-RS	SJ7215S	1 1/8
MR-18-RSS	SJ7215SS	1 1/8
MR-20	SJ7235	1 1/4
MR-20-N	SJ7234	1 1/4
MR-20-RS	SJ7235S	1 1/4
MR-20-RSS	SJ7235SS	1 1/4
MR-22	SJ7255	1 3/8
MR-22-N	SJ7254	1 3/8
MR-22-RS	SJ7255S	1 3/8
MR-22-RSS	SJ7255SS	1 3/8
MR-24	SJ7275	1 1/2
MR-24-N	SJ7274	1 1/2
MR-24-RS	SJ7275S	1 1/2
MR-24-RSS	SJ7275SS	1 1/2
MR-26	SJ7295	1 5/8
MR-26-N	SJ7294	1 5/8
MR-26-RS	SJ7295S	1 5/8
MR-26-RSS	SJ7295SS	1 5/8
MR-28	SJ7315	1 3/4
MR-28-N	SJ7314	1 3/4
MR-28-RS	SJ7315S	1 3/4
MR-28-RSS	SJ7315SS	1 3/4
MR-30	SJ7335	1 7/8
MR-30-N	SJ7334	1 7/8
MR-30-RS	SJ7335S	1 7/8
MR-30-RSS	SJ7335SS	1 7/8
MR-31	SJ7345	1 15/16
MR-32	SJ7355	2
MR-32-N	SJ7354	2
MR-32-RS	SJ7355S	2
MR-32-RSS	SJ7355SS	2
MR-36	SJ8407	2 1/4
MR-36-N	SJ8406	2 1/4
MR-36-RS	SJ8407S	2 1/4
MR-36-RSS	SJ8407SS	2 1/4
MR-40	SJ8447	2 1/2
MR-40-N	SJ8446	2 1/2
MR-40-RS	SJ8447S	2 1/2
MR-40-RSS	SJ8447SS	2 1/2
MR-44	SJ8477	2 3/4
MR-44-N	SJ8476	2 3/4
MR-44-RS	SJ8477S	2 3/4
MR-44-RSS	SJ8477SS	2 3/4
MR-48	SJ8517	3
MR-48-N	SJ8516	3
MR-48-RS	SJ8517S	3
MR-48-RSS	SJ8517SS	3
MR-52	SJ9567	3 1/4
MR-56	SJ9608	3 1/2
MR-56-N	SJ9607	3 1/2
MR-56-RS	SJ9608S	3 1/2
MR-56-RSS	SJ9608SS	3 1/2
MR-60	SJ9648	3 3/4
MR-64	SJ9688	4
MR-68	SJ9728	4 1/4
MR-72	TJ6769	4 1/2
MR-80	SJ6849	5
MR-88	TJ6919	5 1/2
MR-88-N	TJ6918	5 1/2
MR-104-N	SJ6935	6 1/2
MR-116	SJ2326	7 1/4
MR-132	SJ2526	8 1/4

McGill	RBC	Size
MI-6	IR7134	5/8
MI-6-N	IR7133	5/8
MI-8	IR7154	3/4
MI-8-N	IR7153	3/4
MI-9-N	IR7153C	3/4
MI-10	IR7174	7/8
MI-10-N	IR7173	7/8
MI-11-N	IR7173C	7/8
MI-12	IR7194	1
MI-12-N	IR7193	1
MI-13	IR7194C	1
MI-13-N	IR7193C	1
MI-14	IR7215	1 1/8
MI-14-N	IR7214	1 1/8
MI-15	IR7215C	1 1/8
MI-15-N	IR7214C	1 1/8
MI-16	IR7235	1 1/4
MI-16-N	IR7234	1 1/4
MI-17	IR7255D	1 3/8
MI-18	IR7255	1 3/8
MI-18-N	IR7254	1 3/8
MI-19	IR7275	1 1/2
MI-20	IR7275C	1 1/2
MI-20-N	IR7274C	1 1/2
MI-21	IR7295	1 5/8
MI-21-N	IR7294	1 5/8
MI-22-4S	IR7295C	1 5/8
MI-22	IR7315D	1 3/4
MI-23	IR7315	1 3/4
MI-24	IR7315C	1 3/4
MI-24-N	IR7314C	1 3/4
MI-25	IR7355D1	2
MI-25-4S	IR7335	1 7/8
MI-26	IR7355D	2
MI-26-2S	IR7345	1 15/16
MI-27	IR7355	2
MI-28	IR8407	2 1/4
MI-28-N	IR8406	2 1/4
MI-30	IR8407C1	2 1/4
MI-31	IR8447	2 1/2
MI-32	IR8447C	2 1/2
MI-32-N	IR8446C	2 1/2
MI-34	IR8447C1	2 1/2
MI-35	IR8477	2 3/4
MI-36	IR8477C	2 3/4
MI-36-N	IR8476C	2 3/4
MI-38	IR8517	3
MI-39	IR8517C1	3
MI-40	IR8517C	3
MI-40-N	IR8516C	3
MI-42	IR9567D	3 1/4
MI-44	IR9567	3 1/4
MI-47	IR9608	3 1/2
MI-48	IR9608C	3 1/2
MI-48-N	IR9607C	3 1/2
MI-50	IR9648	3 3/4
MI-52	IR9648C	3 3/4
MI-54	IR9688	4
MI-56	IR9688C	4
MI-58	IR9728C	4 1/4
MI-60	IR9728C1	4 1/4
MI-62	IR6769C	4 1/2
MI-64	IR6849	5
MI-68	IR6849C	5
MI-72	IR6919	5 1/2
MI-72-N	IR6918	5 1/2
MI-80	IR6926	6
MI-80-N	IR6925	6
MI-88	IR6936	6 1/2
MI-88-N	IR6935	6 1/2
MI-96	IR2326	7 1/4
MI-104	IR2426	7 3/4
MI-112	IR2526	8 1/4
MI-120	IR2626	8 3/4
MI-128	IR2726	9 1/4

INA	RBC	Size
NCS-1012	SJ7133	5/8
NCS-1016	SJ7134	5/8
NCS-1212	SJ7153	3/4
NCS-1216	SJ7154	3/4
NCS-1412	SJ7173	7/8
NCS-1416	SJ7174	7/8
NCS-1612	SJ7193	1
NCS-1616	SJ7194	1
NCS-1816	SJ7214	1 1/8
NCS-1820	SJ7215	1 1/8
NCS-2016	SJ7234	1 1/4
NCS-2020	SJ7235	1 1/4
NCS-2216	SJ7254	1 3/8
NCS-2220	SJ7255	1 3/8
NCS-2416	SJ7274	1 1/2
NCS-2420	SJ7275	1 1/2
NCS-2616	SJ7294	1 5/8
NCS-2620	SJ7295	1 5/8
NCS-2816	SJ7314	1 3/4
NCS2820	SJ7315	1 3/4
NCS3020	SJ7335	1 7/8
NCS-3220	SJ7355	2
NCS-3624	SJ8406	2 1/4
NCS-4024	SJ8446	2 1/2
NCS-4424	SJ8476	2 3/4
NCS-4824	SJ8516	3
NCS-5228	SJ9567	3 1/4
NCS-5632	SJ9608	3 1/2
NCS6832	SJ9728	4 1/4
PI-081212	IR7153	3/4
PI-081216	IR7154	3/4
PI-101412	IR7173	7/8
PI-101416	IR7174	7/8
PI-121612	IR7193	1
PI-121616	IR7194	1
PI-141816	IR7214	1 1/8
PI-141820	IR7215	1 1/8
PI-162016	IR7234	1 1/4
PI-162020	IR7235	1 1/4
PI-182216	IR7254	1 3/8
PI-182220	IR7255	1 3/8
PI-202420	IR7275C	1 1/2
PI-212616	IR7294	1 5/8
PI-222620	IR7295C	1 5/8
PI-232820	IR7315	1 3/4
PI-242820	IR7315C	1 3/4
PI-253020	IR7335	1 7/8
PI-273220	IR7355	2
PI-283264	IR8406C	2 1/4
PI-283624	IR8407C1	2 1/4
PI-324024	IR8447	2 1/2
PI-364424	IR8477	2 3/4
PI-404824	IR8517	3
PI-445228	IR9568	3 1/4
PI-485632	IR9648	3 3/4



# Pitchlign® Application Sheet

Name: \_\_\_\_\_ Title: \_\_\_\_\_ Date: \_\_\_\_\_

Company: \_\_\_\_\_ Address: \_\_\_\_\_

City: \_\_\_\_\_ State: \_\_\_\_\_ Zip: \_\_\_\_\_

Application: Currently in use: \_\_\_\_\_ New: \_\_\_\_\_

If currently in use, what bearings are now being used? \_\_\_\_\_

Manufacturer: \_\_\_\_\_ Part No.: \_\_\_\_\_

Equipment bearings to be used on: \_\_\_\_\_ Model No.: \_\_\_\_\_

No. bearings per operating unit: \_\_\_\_\_ Anticipated requirements per year: \_\_\_\_\_

Operating Temperature: \_\_\_\_\_ Speeds: \_\_\_\_\_

Loads: \_\_\_\_\_ Desired L-10 Life: \_\_\_\_\_

(Magnitude & Direction)

Intermittent (Describe): \_\_\_\_\_ Shock: \_\_\_\_\_

Shaft:

Horizontal: \_\_\_\_\_ Angular: \_\_\_\_\_ Oscillating (Angle: \_\_\_\_\_) Vertical: \_\_\_\_\_

Rotating: \_\_\_\_\_ Stationary: \_\_\_\_\_ Potential shaft or housing deflection: \_\_\_\_\_

Degree of expected misalignment: \_\_\_\_\_ Housing Material: \_\_\_\_\_

Shaft Material: \_\_\_\_\_ Shaft Heat Treat (Inner race omitted): \_\_\_\_\_

Lubrication:

Type: \_\_\_\_\_ Method: \_\_\_\_\_ Cycle: \_\_\_\_\_

If CF type, are all oil holes needed? Yes: \_\_\_\_\_ No: \_\_\_\_\_

For Gear Pump Calculations, the following additional information is required:

Operating pressure in PSI: \_\_\_\_\_ RPM: \_\_\_\_\_

No. of Teeth: \_\_\_\_\_ Gear Pitch: \_\_\_\_\_ Gear Width: \_\_\_\_\_

Percentage or time of duty at operating pressure - Test Basis: \_\_\_\_\_

Percentage or time of duty at operating pressure - Field Basis: \_\_\_\_\_

For Gear Trains, the following additional information is required along with a print:

Horsepower Input: \_\_\_\_\_ Distance between Gears: \_\_\_\_\_ Helix Angle: \_\_\_\_\_

Input Speed: \_\_\_\_\_ Pitch Diameters: \_\_\_\_\_ Spiral Angle: \_\_\_\_\_ No. of Teeth: \_\_\_\_\_

If Spiral or Helical Gearing:

Direction of Driving Pinion: \_\_\_\_\_ Hand of Spiral or Helix: \_\_\_\_\_

Pitchlign<sup>®</sup> Application Data and Sketches:

---

---

---

---

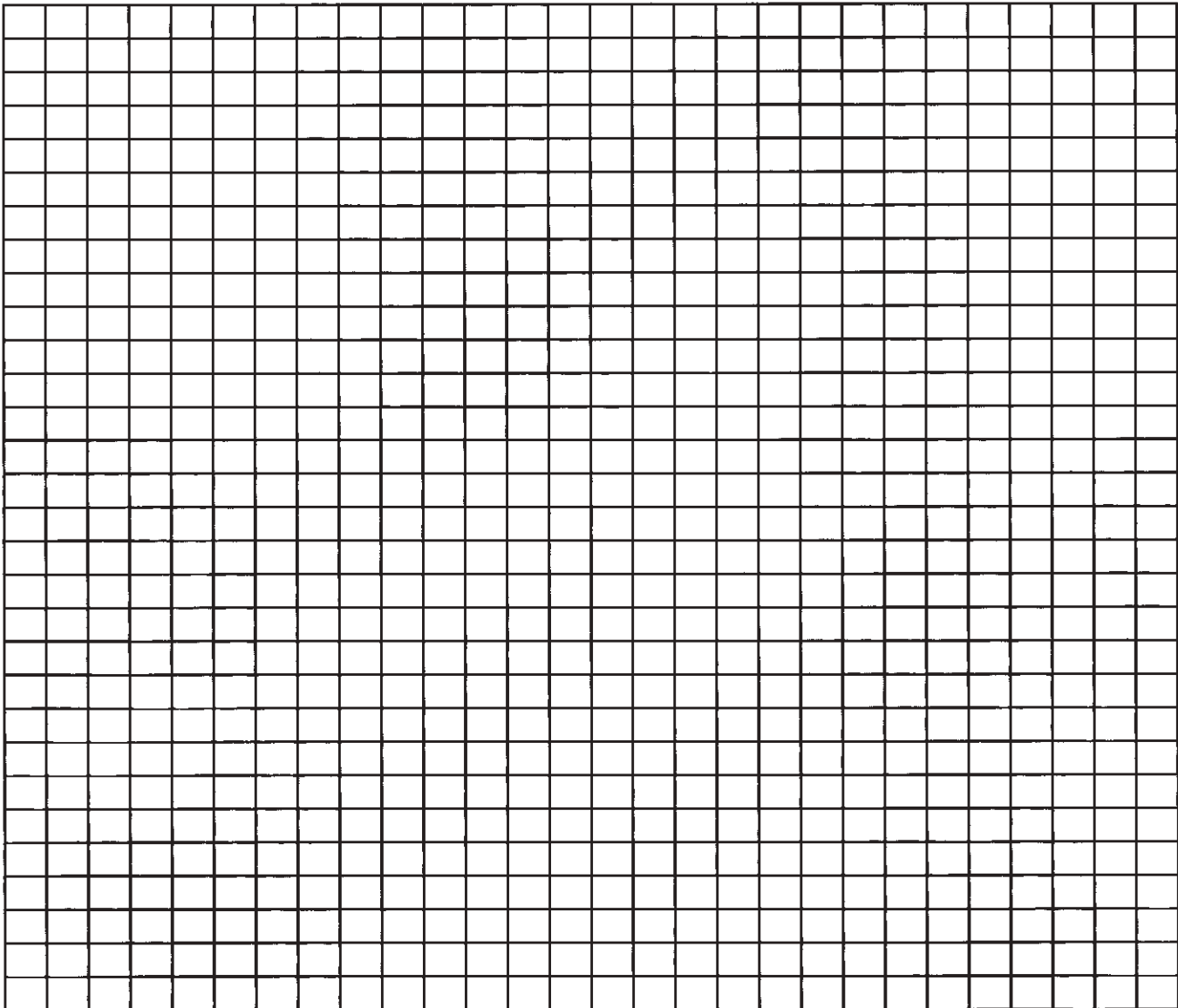

Please attach any relevant drawings and send to:

RBC Bearings  
400 Sullivan Way  
West Trenton, NJ 08628  
800.390.3300  
Fax: 609.882.5533

# CUSTOM DESIGNED BEARINGS

As we mentioned earlier in this reference catalog, in addition to our complete line of standard bearings, RBC also will manufacture many other bearings of a highly specialized nature for specific applications. As each special bearing is engineered for a particular set of operating conditions, it is essential that we have complete data regarding the application, including potential production volumes.

Shown below are just a few of our custom designed Bearings.



**Helicopter Rotor Bearing with  
Inner Ring M50 Steel**



**Aircraft Transmission Bearing**



**Reverse Idler Bearing  
Truck Transmission**



**Outboard Engine  
Crankpin Bearing**



**Motorcycle Transmission Bearing**

# Innovation. Commitment. Quality.

RBC Bearings has been producing bearings in the USA since 1919. In addition to unique custom bearings, RBC offers a full line of standard industrial and aerospace bearings, including:



## Spherical Plain Bearings

Radial, angular contact, extended inner ring, high misalignment. QuadLube®, ImpactTuff®, SpreadLock® Seal, CrossLube®, DuraLube™, and self-lubricating bearings. Available in inch and metric sizes.



## Needle Roller Bearings

Pitchlign® caged heavy duty needle roller bearings, inner rings, TJ TandemRoller® bearings for long life.



## Thin Section Ball Bearings

Standard cross sections to one inch. Sizes to 40 inches. Stainless steel and other materials are available. Seals are available on all sizes and standard cross sections. Super duplex configurations.



## Self-Lubricating Bearings

Radial, thrust, rod ends, spherical bearings, high temperature, high loads. Available in inch and metric sizes. Fiberglide® self-lubricating bearings.



## Tapered Roller Bearings

Tyson® case-hardened and through-hardened tapered roller bearings. Available in many sizes. Used in Class 8 heavy truck and trailer wheel bearings, gear boxes, and final drive transmissions.



## Airframe Control Bearings

Ball bearing types, self-lubricating types, needle roller track rollers.



## Tapered Roller Thrust Bearings

Case-hardened. Sealed and unsealed for truck, tractor, and construction equipment steer axles, and Class 8 trailer landing gear.



## Dowel Pins, Loose Needle Rollers, Shafts

Precision Products dowel pins, loose needle rollers, and shafts.



## Ball Screws

Precision ground, rolled, ball splines. Long life, low wear, high accuracy. QuickTurn® Ball Screw Repair Service.



## Commercial Rod Ends

Commercial and industrial, precision, Mil-Spec series, self-lubricating, and aircraft. Sold under the Heim®, Unibal®, and Spherco® brands. Available in inch and metric sizes.



## Integrated Assemblies

For robots and other process tool applications. Engineering design assistance. Production volume capacity.



## Ball Bearings

Precision ground, semi-ground, unground. High loads, long life, smooth operation. Nice® ball bearings are offered in caged and full complement configurations.



## Cam Followers

Standard stud, heavy stud, yoke type, caged roller followers. Patented RBC Roller® cylindrical roller cam followers, HexLube® universal cam followers, airframe track rollers.



## Specials

RBC manufactures many specialty bearings for the aerospace, oil and energy, semiconductor equipment, packaging, transportation, and other industries.