



### LUBE STATION OILER WITH MULTI-POINT DIVIDER BLOCK

#### PROGRAMMABLE LUBRICATOR

Built-in programmable timer for fixed times between reservoir refills. Self-contained battery or electric VAC supply options available.

#### EASY FILL RESERVOIR WITH STRAINER

Wide oil cap provides easy fills. Oil inlet wire mesh strainer protects ingress of foreign material or contaminants. Clear plastic reservoir provides easy read oil levels.

#### POSITIVE VOLUMETRIC DISPLACEMENT

Both lubricator and distributor piston outputs remain stable over a wide temperature range.

#### FLEXIBLE MULTI-POINT KITS

Distribution blocks are offered in 4, 6 and 8 point kits with tubing and fittings. Discharge couplers are available for fewer points.

#### ACCESSORIES FOR QUICK INSTALLATIONS

A comprehensive offering of fittings and adapters are available, including push-in instant tube fitting connections.



### INDUSTRIES SERVED

- Air Conditioning
- Beverage
- Commercial Laundries
- Dairy
- Food Processing
- Lumber
- Metal Forming
- Printing
- Textiles
- Automotive
- Brewing
- Conveyor, Material Handling
- Elevators and Escalators
- Heating and Ventilation
- Machine Tools
- Packaging
- Port Facilities
- Waste Treatment



## Centralized Lubrication Solutions

### LUBE STATION OILER WITH MULTI-POINT DIVIDER BLOCK

#### GENERAL DESCRIPTION

The Lube Station Oiler comprises a positive displacement oil pump used in conjunction with a progressive movement divider block. Divider outlets deliver equal amounts to bearings. This arrangement provides predictable oil deliveries to multiple feeds over a fixed time period.

Normally, the system handles up to eight lubrication points.

#### SETTINGS VERSUS RESERVOIR DISCHARGE PERIODS

Takes the guesswork out of lubricating your machinery. Lubricator has a built-in program switch with eight settings, including ON/OFF and continuous run feature. Lube cycle OFF times are controlled by DIP switch setting.

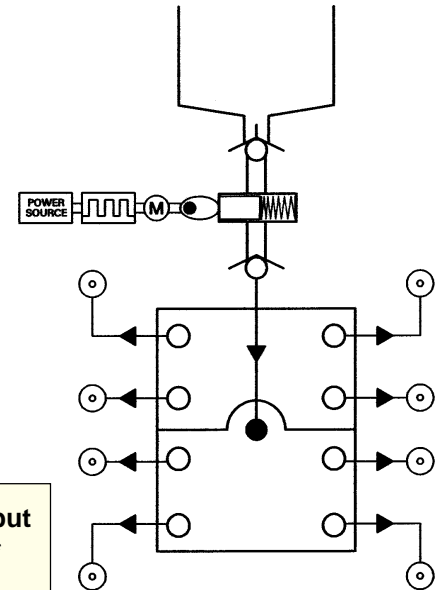

DIP Switch Position (ON)	Lube Cycle OFF Time	Reservoir Replacement Period	Strokes Per Day	Daily Output in cc's *
1	Power ON/OFF	-----	-----	-----
2	Continuous Run	-----	-----	-----
3	24 Hours	480 Days	1	0.5
4	8 Hours	160 Days	3	1.5
5	3 Hours	60 Days	8	4
6	2 Hours	40 Days	12	6
7	1 Hour	20 Days	24	12
8	40 Minutes	13.2 Days	36	18

#### ORDERING

Part No.	Description
LS805-8TO	8 oz. Refillable LubeSite Oiler, 6VDC, Battery Operated
LS805-8TAO	8 oz. Refillable LubeSite Oiler with VAC 94-240V converter
32631-2	2 Point Multi-Point Oil Divider Block Kit with tubing and fittings
32631-4	4 Point Multi-Point Oil Divider Block Kit with tubing and fittings
32631-6	6 Point Multi-Point Oil Divider Block Kit with tubing and fittings
32631-8	8 Point Multi-Point Oil Divider Block Kit with tubing and fittings

Note: Order a horizontal outlet port coupler to combine two outlets to make an odd number kit.

Illustrations and specifications are not binding in detail. Designs are subject to modification and improvement without notice.

